

# SCIAENGINEER

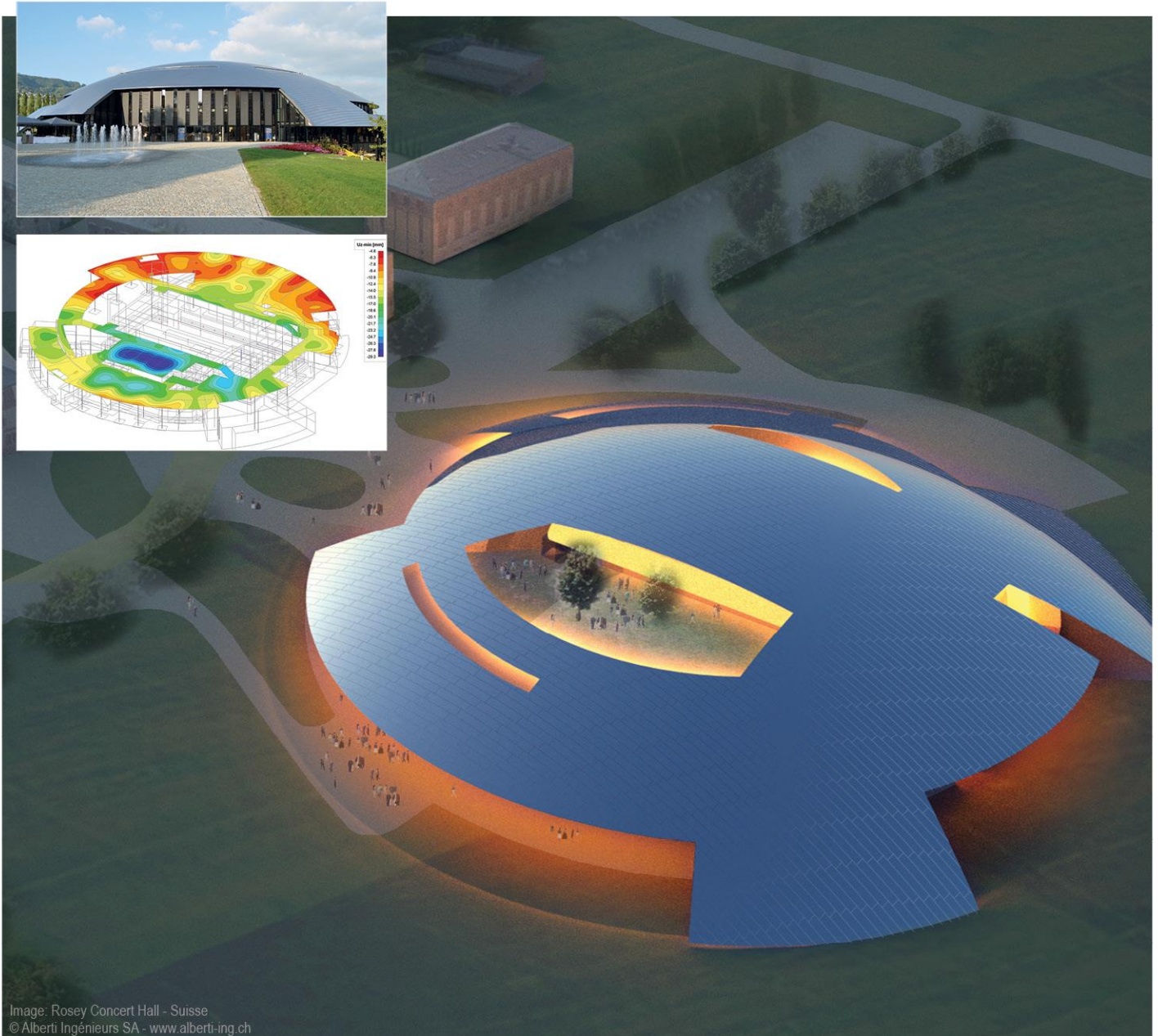

## Advanced Package Training Scaffolding

All information in this document is subject to modification without prior notice. No part of this manual may be reproduced, stored in a database or retrieval system or published, in any form or in any way, electronically, mechanically, by print, photo print, microfilm or any other means without prior written permission from the publisher. SCIA is not responsible for any direct or indirect damage because of imperfections in the documentation and/or the software.

© Copyright 2015 SCIA nv. All rights reserved.

## Table of contents

Table of contents.....	3
1. Introduction .....	2
2. Model .....	3
General .....	3
Materials .....	4
Cross sections.....	5
Construction - linear .....	5
END INPUT OF CONSTRUCTION.....	9
3. Load cases and combinations.....	10
Load cases .....	10
Combinations .....	17
4. Results .....	20
5. Scaffolding SLS Check – EN 12811-1 .....	21
6. Scaffolding ULS Check – EN 12811-1-1 .....	23
General .....	23
Scaffolding check in SCIA Engineer .....	24
7. Non-Linear Combinations .....	26
Overview .....	26
Alpha critical.....	29
Global frame imperfection $\varphi$ .....	29
Initial bow imperfection $e_0$ .....	31
8. The second order calculation .....	33
Timoshenko .....	33
Newton Raphson .....	35
9. Stability .....	39
Linear Stability.....	39
Manual calculation of $K_G$ .....	41
Buckling Shape .....	42
10. Input Hinge Types and non-linear stiffness .....	50
Couplers.....	50
Non linear gaps for bracings .....	56
Non linear supports .....	57
11. Scaffolding Non linear Check .....	58
Relative deformation Check (SLS) .....	58
Scaffolding Check (ULS) .....	59
12. Scaffolding – Coupler Check .....	60
Checking the internal forces .....	60
Interaction check.....	61
13. Aluminium.....	65
14. Engineering Report.....	66
15. Template.....	67
16. User Blocks.....	68
17. Attributes .....	70
18. References .....	73
19. Annex A: Wind pressure versus Wind force .....	74





## 1. Introduction

This course has been made for the scaffolding package of SCIA Engineer. In this package the following modules are included:

<b>Module</b>	<b>Description</b>
esa.00	1D member modeller
esa.01	Planar 2D members
esa.06	Productivity toolbox
esas.29	Surface load generators
esas.00	Linear statics 2D
esas.01	Linear statics 3D
esas.07	Tension only members
esas.08	Pressure only support of soil
esas.09	Nonlinear springs, gaps
esas.42	Friction springs
esas.10	Geometrical nonlinear of frames
esas.13	Stability analysis of frames
esasd.01.01	Steel code check – EN 1993-1-1
esasd.13.01	Scaffolding checks - EN 12811-1
esadt.01	Automated GA drawings

If other modules are necessary to perform a specific action described in this manual, it will be indicated.

## 2. Model

### General

The objective of this manual is to show a way of modelling a scaffolding (class 3) using SCIA Engineer. In this manual a simple example is elaborated.

The following scaffolding will be treated in this course:

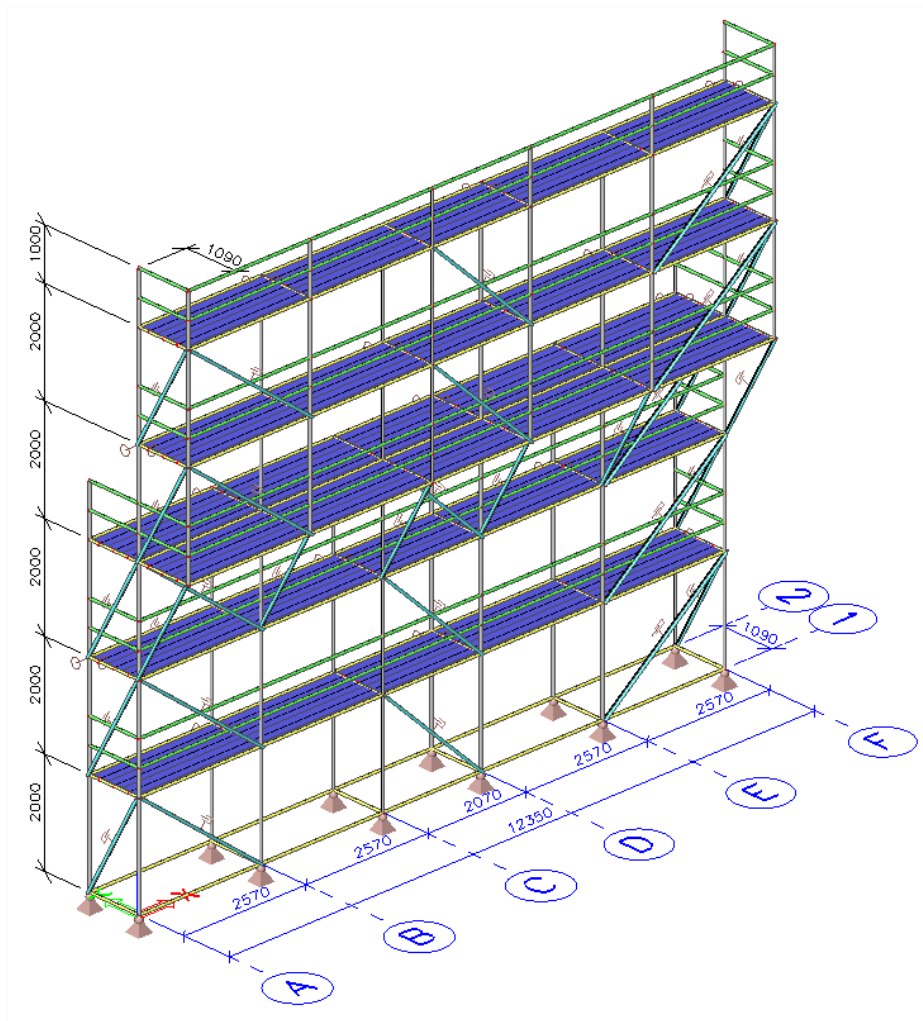

When entering the project, the following project data are chosen:

Frame XYZ  
 Project Level: Advanced  
 Material: S235  
 National Code: EC-EN

and the following functionalities:

Non-linearity (+ all options for non linearity on the right hand side)  
 Scaffolding  
 Stability

## Materials

For the materials, S235 is generally used. However, floor boards and toeboards will be inserted as members. The average weight of these toeboards and floor boards differs from the weight of S235. That is why it is chosen to insert an extra material in SCIA Engineer, in which the weight will be adapted. This weight can be determined as shown below:

### FLOOR BOARDS

A distinction is made between floor boards of 19cm and 32cm. For each of them an average weight is calculated:

Name	Weight [kg]	Length [m]	[kg/m]	Average
Steel board 32/307	23.2	3.07	7.56	<b>8.20 kg/m</b>
Steel board 32/257	19	2.57	7.39	
Steel board 32/207	15.7	2.07	7.58	
Steel board 32/157	12.2	1.57	7.77	
Steel board 32/140	10.8	1.4	7.71	
Steel board 32/109	10.4	1.09	9.54	
Steel board 32/73	7.2	0.73	9.86	
Steel board 19/307	18.2	3.07	5.93	<b>6.18 kg/m</b>
Steel board 19/257	15.5	2.57	6.03	
Steel board 19/207	12.7	2.07	6.14	
Steel board 19/157	10	1.57	6.37	
Steel board 19/109	7	1.09	6.42	

It is assumed that the floor boards have a thickness of 1 cm (instead of 4 cm to reduce the stiffness). The weights of the floor boards are:

$$\Rightarrow \text{Floor boards } 0.32\text{m: } \rho = \frac{8,2 \text{ kg/m}}{0,32\text{m} \cdot 0,04\text{m}} = 640,6 \text{ kg/m}^3$$

$$\Rightarrow \text{Floor boards } 0.19\text{m: } \rho = \frac{8,2 \text{ kg/m}}{0,19\text{m} \cdot 0,04\text{m}} = 1079,0 \text{ kg/m}^3$$



## Cross sections

Below all cross sections used in the construction are displayed:

	<b>Cross section</b>	<b>Material</b>
Standard	RO48.3x3.2	S235
Ledger	RO48.3x3.2	S235
Guardrail	RO48.3x3.2	S235
Bracing	RO48.3x2.3	S235
Floor board – 0.32m	RECT (40; 320)	FB 0.32
Floor board – 0.19m	RECT (40; 190)	FB 0.19
Tube	RO48.3x3.2	S235

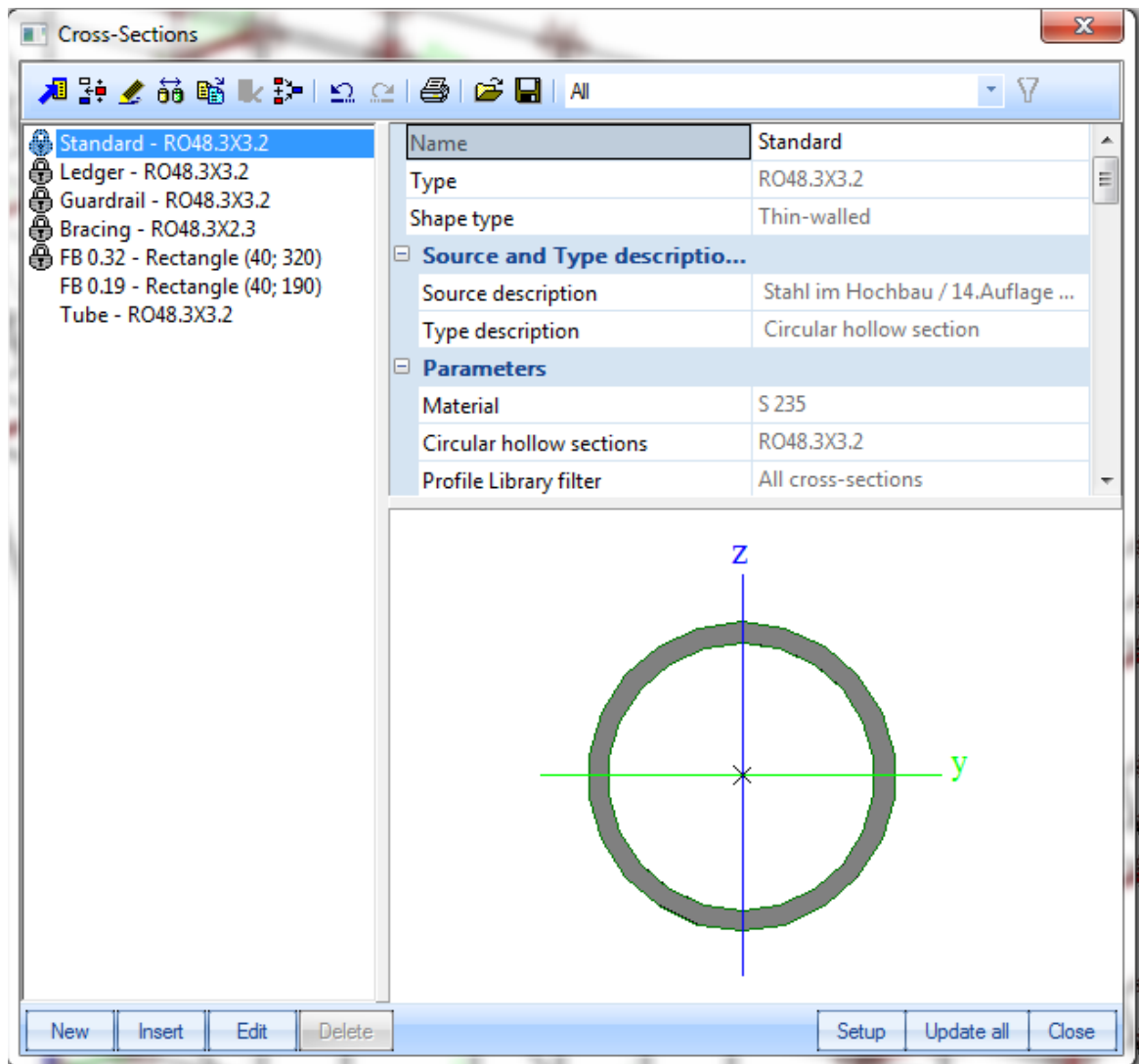

## Construction - linear

The construction will be entered as a 3D Frame for the first level. Afterwards this level is copied upward. The type of all members in this frame is entered correctly:

- Columns: column
- Ledgers: beam
- Bracings: vertical wind bracing
- Hinges
- Supports

## FLOOR BOARDS

The input of floor board elements depends on the length of the ledgers. In the picture below all the possibilities are displayed. The total length of the ledger is shown at the bottom. The distance of the points, on which the floor board has to be entered, is displayed at the top.

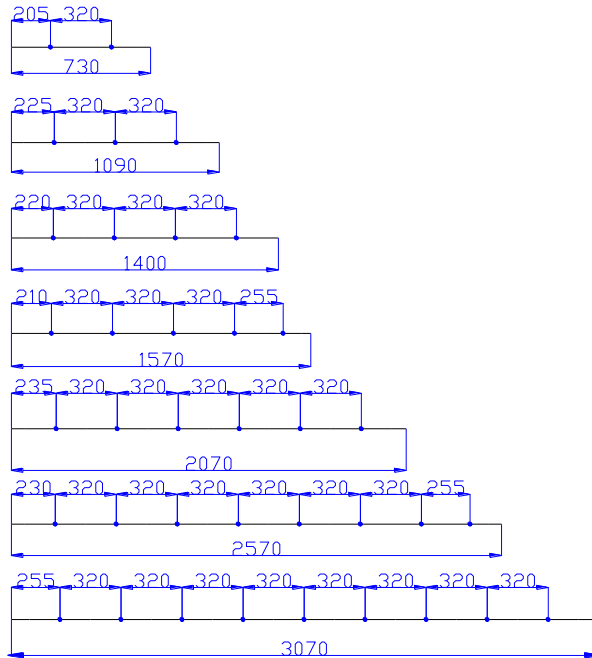

## BRACINGS

The wind bracings are entered with an eccentricity in the y direction of 48.3 mm (width of the profile):  $e_y = \pm 48.3\text{mm}$ . This way the wind bracings are truly on top of the other members and not in between:

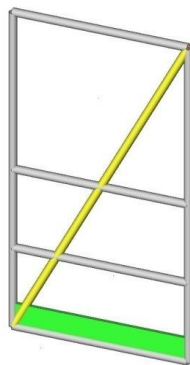

Without eccentricity

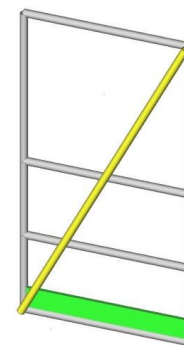

With eccentricity

## CONNECTIONS

### Standard – Standard connections

The overlap length between two columns is 200 mm > 150 mm, so the columns are rigid in the x - direction.

Moreover, the margin between two columns is 3.9 mm ( $=48.3\text{ mm} - 2 \times 3.2\text{ mm} - 38\text{ mm}$ ), this is less than 4 mm. Because of this, also the connection in the y and z direction are rigid.

According to the code, also the following applies:

- ⇒ According to code EN12811-1, the connection column - column can be considered **rigid** in the modelling
- ⇒ A hinge will not be entered at the extremities on the standard

## Standard – Toeboard and Ledger – Floor board connections

- y direction: Hinged
- z direction: Rigid

## Standard – Bracing connections

- y direction: Hinged
- z direction: Rigid

## Standard–Ledger and Standard–Guardrail connections

Or input a certain flexibility in the two directions, for example:

- y direction: 0,10 MNm/rad
- z direction: 0,005 MNm/rad

These rigidities are obtained from data from the supplier. In this case, the rigidity for the y direction is taken from the supplier and a smaller value is taken for the z direction. Of course, this is not a correct method. Both should be obtained from data from the supplier.

Or choose a “hinge” from our library in SCIA Engineer:

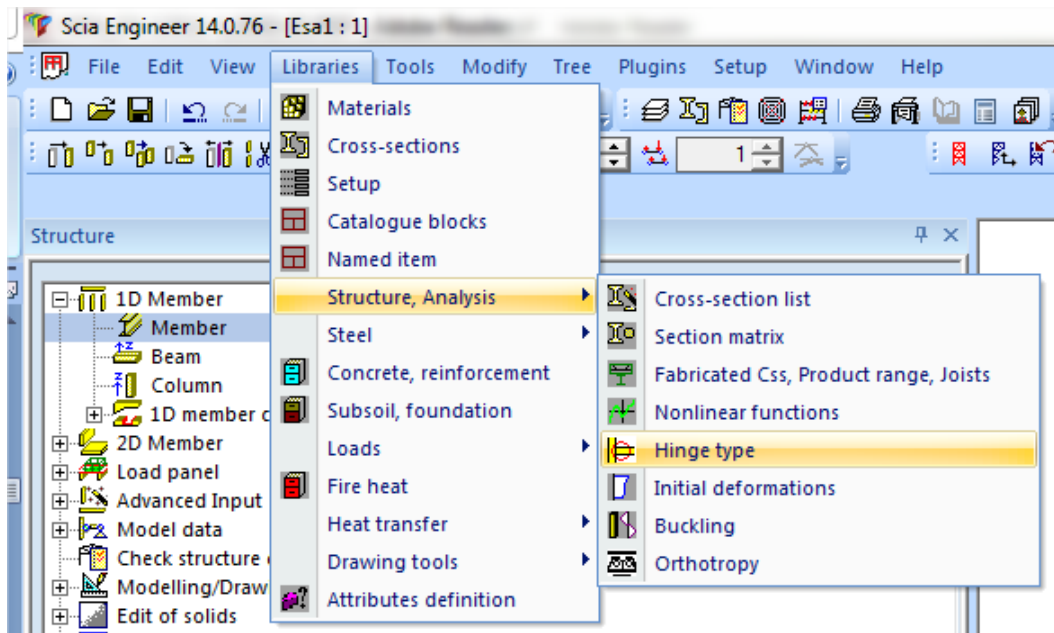

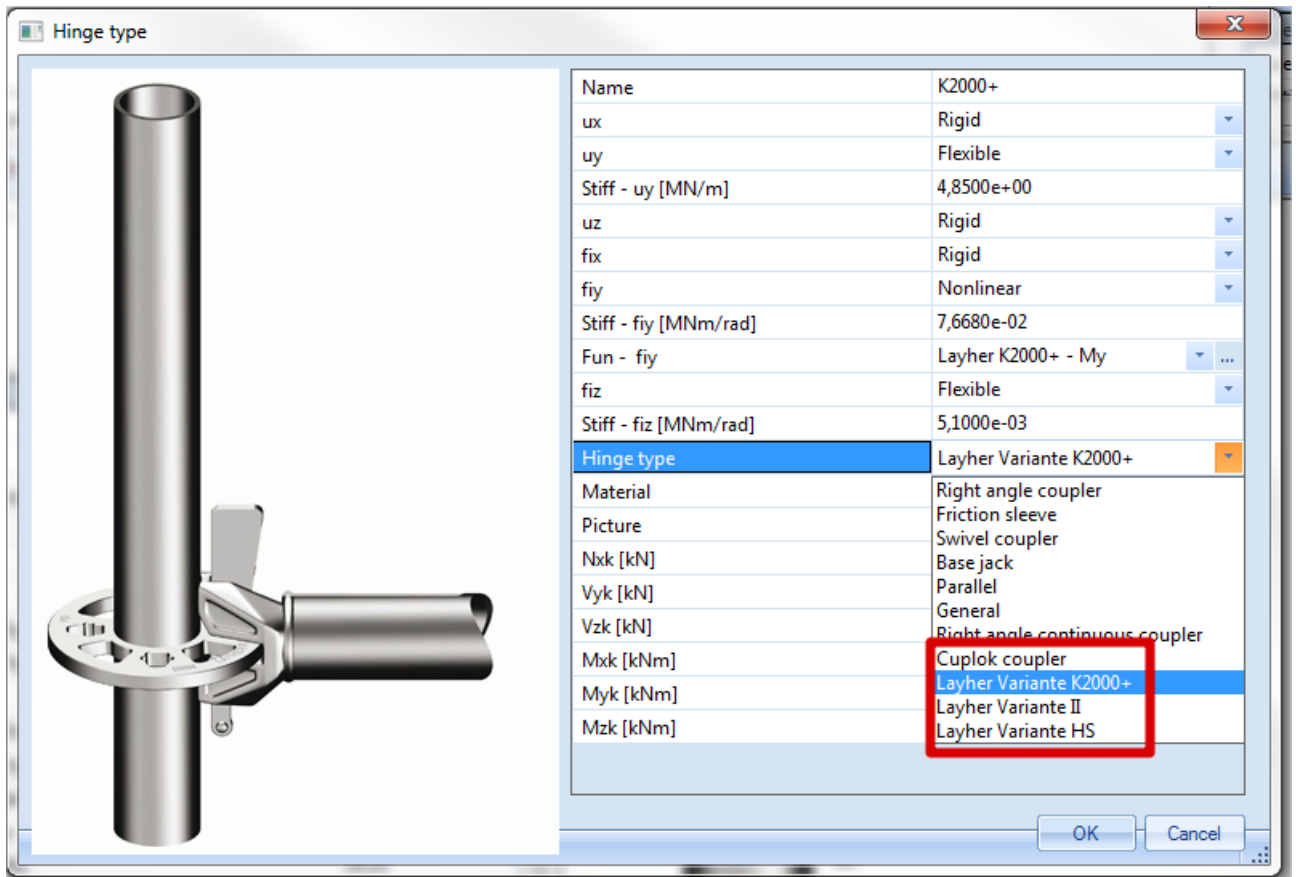

And input this hinge on all ledgers and guardrails.

For those hinges the linear stiffness is input already. The principle about the non linear stiffness will be explained later in this course.

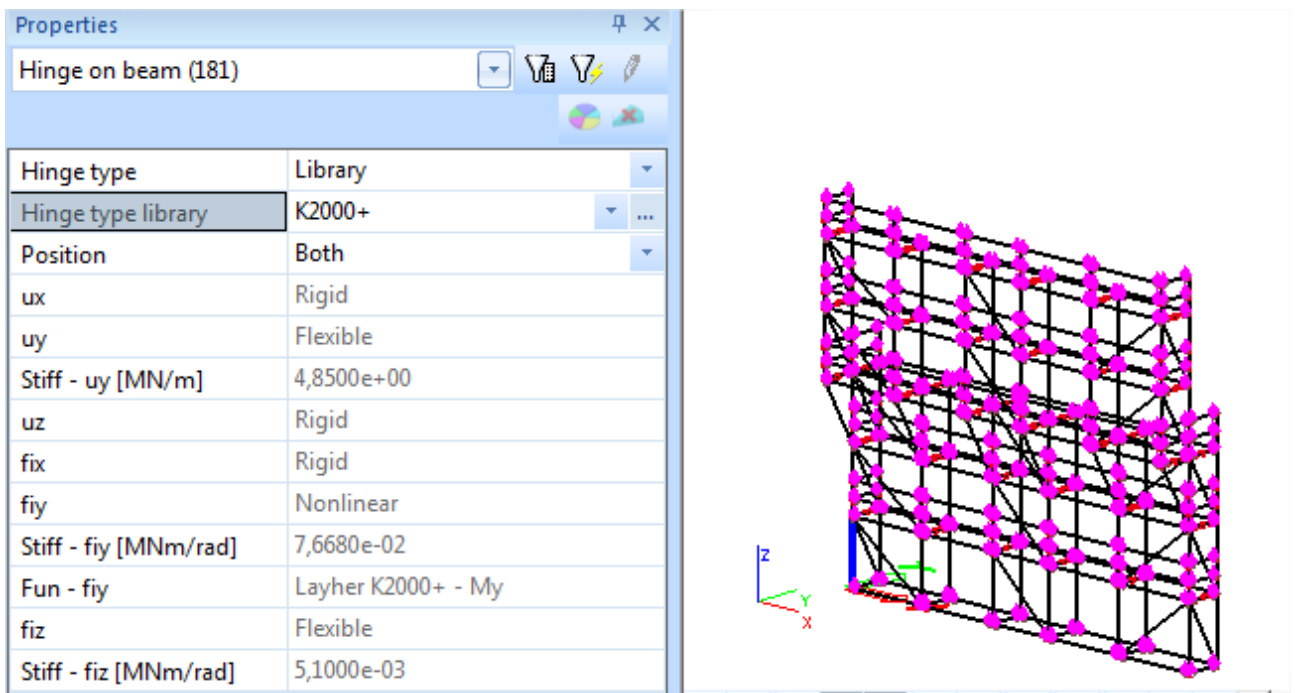

## SUPPORTS

There are two types of supports: the base jacks at the bottom and the anchorages in the wall.

For the **base jacks**, translations in all directions are fixed (**Translations X, Y and Z fixed**). For the anchorages, only the translations according to the x and y direction are fixed (**Translations X and Y fixed**).

The **anchorages** are introduced according to the anchorage scheme: from 4m high, **every** standard has to be anchored every 4 m upward. Over 20 m high, this needs to be performed every 2 m upward.

## END INPUT OF CONSTRUCTION

After entering the construction, it is recommended to check the input by using the command "**Check Structure Data**". Through this function the geometry is checked on errors.

After the check, the option "**Connect nodes/edges to members**" is applied to the entire construction. With this function the different parts are connected to each other.

### 3. Load cases and combinations

#### Load cases

##### Type of load cases in EN 12811-1

There are three main types of loads which need to be considered [EN12811-1, 6.2.1.]:

- Permanent loads: these shall include the self weight of the scaffold structure, including all components, such as platforms, fences, fans and other protective structures and any ancillary structures such as hoist towers.
- Variable loads: these shall include service loads (loading on the working area, loads on the side protection) and wind loads and, of appropriate, snow and ice loads.
- Accidental loads

The **permanent** loads are inputted as the self weight in SCIA Engineer.

The only **accidental** load specified in the European Standard is the downward loading on the side protection [more info in EN12811-1, 6.2.5.1].

The **variable** loads can be considered as the service loads and the wind load.

The **service loads** are considered in Table 3 of EN 12811-1:

Table 3 — Service loads on working areas (see also 6.2.2)

Load class	Uniformly distributed load $q_1$ kN/m <sup>2</sup>	Concentrated load on area 500 mm x 500 mm $F_1$ kN	Concentrated load on area 200 mm x 200 mm $F_2$ kN	Partial area load	
				$q_2$ kN/m <sup>2</sup>	Partial area factor $a_p$ <sup>1</sup>
1	0,75 <sup>2</sup>	1,50	1,00	---	---
2	1,50	1,50	1,00	---	---
3	2,00	1,50	1,00	---	---
4	3,00	3,00	1,00	5,00	0,4
5	4,50	3,00	1,00	7,50	0,4
6	6,00	3,00	1,00	10,00	0,5

Each working area is capable of supporting the various loadings  $q_1$ ,  $F_1$  and  $F_2$ , separately but not cumulatively.

##### **$q_1$ : Uniformly distributed service load (EN12811-1, 6.2.2.2)**

Each working area is capable of supporting the uniformly distributed loads,  $q_1$  as specified in the table above.

##### **$F_1$ and $F_2$ : Concentrated load (EN12811-1, 6.2.2.3)**

Each platform unit is capable of supporting the load  $F_1$  uniformly distributed over an area of 500mm x 500mm and, but not simultaneously,  $F_2$  uniformly distributed over an area of 200mm x 200mm.

The position of each load is chosen to give the most unfavourable effect.

When a platform unit is less than 500mm wide, the load may be reduced for this unit in proportion to its width, except that in no case shall the loading be reduced to less than 1,5kN.

**$q_2$ : Partial area load (EN12811-1, 6.2.2.4)**

This load has to be applied only for classes 4, 5 and 6. In those cases each platform is capable of supporting a partial area loading  $q_2$  on an area  $A_{q2}$ :

$$A_{q2} = l \cdot w \cdot a_p$$

With:

- $l$       The length
- $w$       The width
- $a_p$       Coefficient of Table 3

The dimensions and position of the partial area are chosen to give the most unfavourable effect. One example is shown below:

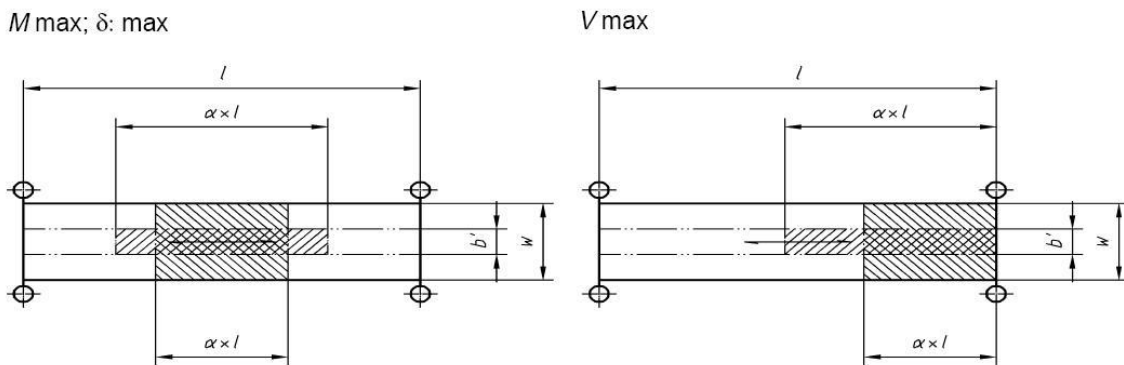

$$b' \leq a_p \times w: \quad \alpha = 1$$

$$a_p \times w \leq b' \leq w: \quad \alpha = a_p \times \frac{w}{b'}$$

**Wind load**

Following 6.2.7.4 of EN12811-1, two wind loads have to be calculated: the maximum wind load and the working wind load.

**Maximal wind load**

When the European Standard for wind loads is available it is used for the calculation of the maximal wind load.

To make allowance for equipment or materials which are on the working area, a nominal reference area is assumed at its level over its full length. This area is 200mm and includes the height of the toeboard. (En 12811-1, 6.2.7.4.1)

*Note: For the purposes of structural design of façade scaffolds made of prefabricated components, design velocity pressures are given in EN 12810-1, 8.3.*

**Working wind load**

A uniformly distributed velocity pressure of 0,2 kN/m<sup>2</sup> is taken into account. To make allowance for equipment or materials which are on the working area, a nominal reference area is assumed. This area is 400mm and includes the height of the toeboard. (En 12811-1, 6.2.7.4.2)

**Area of wind loading**

The wind load is inputted as an area load. The amount of this load, depends on the amount of the loaded area itself, so without cladding a smaller wind load will be inserted than with cladding or netting.

**Load cases in SCIA Engineer**

The following load cases will be inputted in SCIA Engineer:

**Load Case 1: Self Weight**

In this load case the complete self weight of the structure is included, including the toeboards, floor board elements, ...

This load case is automatically calculated by SCIA Engineer.

**Load Case 2: Self Weight of the toeboards (and other structural members)**

The self weight of the toeboards can be calculated as follows:

Surface area of the profile = 15 cm x 2 cm = 30 cm<sup>2</sup> = 30 x 10<sup>-4</sup> m<sup>2</sup>  
Density of the toeboard = 773.3 kg/m<sup>3</sup>

Weight of the toeboard per meter = 30 x 10<sup>-4</sup> m<sup>2</sup> x 773.3 kg/m<sup>3</sup> = 2.32 kg/m

Line load: 2.32 x 9.81 N/m = 22,76 N/m = 0,023 kN/m

**Load Case 3: Service load work condition**

This load case represents the service load that operates over the entire main floor. "Main floor" means the most important/crucial floor of the scaffolding. If the load is put on this floor, it leads to the most critical values.

In this example, a class 3 scaffolding has been inserted, so a divided load of 200 kg/m<sup>2</sup>, or 2 kN/m<sup>2</sup> (EN12811-1 Table 3). This is transferred to floor boards.

Analogous above, also a service load is entered on the complete secondary floor. Secondary floor refers to the working area at the first level above or below the main floor.

According to the code EN12811-1, 50% of the service load has to be put on the secondary floor.

**Load Case 4: Service load Max wind**

This load case represents an accumulation of materials and equipments for the complete main working area, when the scaffolding is subject to the maximal wind load.



**Note**

In some cases it can be necessary to input a non symmetric load on the construction. So it can be important to input a load case, completely analogous to load case 3, 4 or 5, but here the service load is only put on half of the main floor. By executing this load case, the structure is eccentrically loaded, so effects that counterbalance each other in a symmetrical load, are revealed here.

Example:

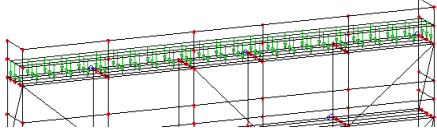
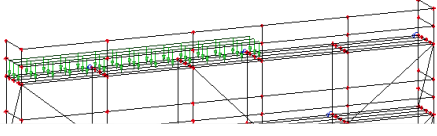
Full loaded	
Half loaded	

**Load Case 5: Maximal Wind load Perpendicular to Facade**

Since the arithmetic method for the calculation of a wind load from code EN12811-1 is not valid for all scaffoldings, provided by nets that completely surround the construction, the code EN 1991-1-4 is adopted.

There are three cases for calculating a reference height (EN1991-1-4, Figure 7.4)

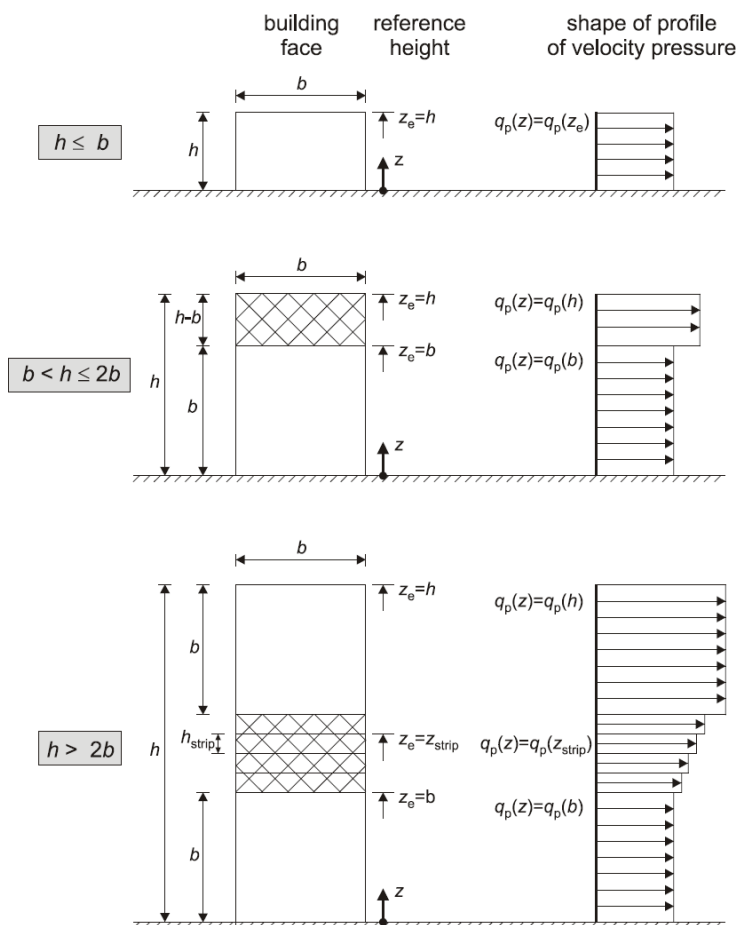

In the example discussed in this course, the height is 11m and the building face is 12,35m. So in this case clearly  $11\text{m} \leq 12,35\text{m}$  and thus  $h \leq b$ . So the wind only has to be calculated for  $z_e = 11\text{m}$ .

In this example, the wind is calculated for a construction without nets, situated in Belgium with a terrain category of III.

The terrain category is determined as follows (EN 1991-1-4, Table 4.1):

	<b>Terrain category</b>	<b><math>z_0</math> [m]</b>	<b><math>z_{\min}</math> [m]</b>
0	Sea or coastal area exposed to the open sea	0,003	1
I	Lakes or flat and horizontal area with negligible vegetation and without obstacles	0,01	1
II	Area with low vegetation such as grass and isolated obstacles (trees, buildings) with separations of at least 20 obstacle heights	0,05	2
III	Area with regular cover of vegetation or buildings or with isolated obstacles with separations of maximum 20 obstacle heights (such as villages, suburban terrain, permanent forest)	0,3	5
IV	Area in which at least 15% of the surface is covered with buildings and their average height exceeds 15m	1,0	10

For Belgium,  $v_{b,0}$  equals 26.2m/s following the EC-EN. In addition  $C_{dir}$  and  $C_{season}$  are all equal to 1. From this  $v_b$  can be calculated (EN 1991-1-4 (4.1)):

$$\begin{aligned} v_b &= C_{dir} \cdot C_{season} \cdot v_{b,0} \\ &= 26,2\text{m/s} \end{aligned}$$

In terrain class III the mean velocity  $v_m$  are calculated using the following formula (EN 1991-1-4 (4.3)):

$$v_m = c_r(z) \cdot c_o(z) \cdot v_b$$

where

$c_o(z)$  is the orography factor taken as 1,0 (unless specified otherwise in EN 1991-1-4 §4.3.3.)

and  $c_r(z)$  is the roughness factor given by formula (EN 1991-1-4 (4.4)):

$$c_r(z) = k_r \cdot \ln\left(\frac{z}{z_0}\right) \quad \text{For} \quad z_{\min} \leq z \leq z_{\max}$$

$$c_r(z) = c_r(z_{\min}) \quad \text{for} \quad z \leq z_{\min}$$

$$\text{And } k_r = 0,19 \left( \frac{z_0}{z_{0,II}} \right)^{0,07} \quad (\text{EN 1991-1-4 (4.5)})$$

The evaluations of these formulas for this example and category III gives:

$$k_r = 0,19 \left( \frac{z_0}{z_{0,II}} \right)^{0,07} = 0,19 \left( \frac{0,3}{0,05} \right)^{0,07} = 0,215$$

$$c_r(z) = k_r \cdot \ln \left( \frac{z}{z_0} \right) = 0,215 \cdot \ln \left( \frac{11}{0,3} \right) = 0,776$$

And the mean velocity:

$$v_m = c_r(z) \cdot c_o(z) \cdot v_b = 0,776 \cdot 1 \cdot 26,2 = 20,3 \text{ m/s}$$

Out of these values the peak velocity pressure is calculated by:

$$q_p(z) = c_e(z) \cdot q_b = c_e(z) \cdot \frac{1}{2} \cdot \rho \cdot v_b^2$$

where

$$\rho = 1,25 \text{ kg/m}^3$$

$$c_e(z) = [1 + 7 \cdot I_v(z)] \cdot (c_r(z))^2 \cdot (c_0(z))^2$$

$$I_v(z) = \frac{k_l}{c_0(z) \cdot \ln \left( \frac{z}{z_0} \right)} \quad \text{for } z_{\min} \leq z \leq z_{\max}$$

$$I_v(z) = I_v(z_{\min}) \quad \text{for } z \leq z_{\min}$$

$k_l$  is the turbulence factor. The recommended value for  $k_l$  is 1,0.

These formulas evaluated for this example and category III gives:

$$I_v(z) = \frac{k_l}{c_0(z) \cdot \ln \left( \frac{z}{z_0} \right)} = \frac{1,0}{1,0 \cdot \ln \left( \frac{11}{0,3} \right)} = 0,278$$

$$c_e(z) = [1 + 7 \cdot I_v(z)] \cdot (c_r(z))^2 \cdot (c_0(z))^2 = [1 + 7 \cdot 0,278] \cdot (0,776)^2 \cdot (1,0)^2 = 1,77$$

That way, the total external pressure is obtained by:

$$q_p(z) = c_e(z) \cdot \frac{1}{2} \cdot \rho \cdot v_b^2 = 1,77 \cdot \frac{1}{2} \cdot 1,25 \cdot (26,2)^2 \text{ N/m}^2 = 760 \text{ N/m}^2 = 0,76 \text{ kN/m}^2$$

Furthermore, we can assume that the members in the plane perpendicular on the wind load take up about 1/5 (=20%) of the total surface of the construction, as shown on the drawing below:

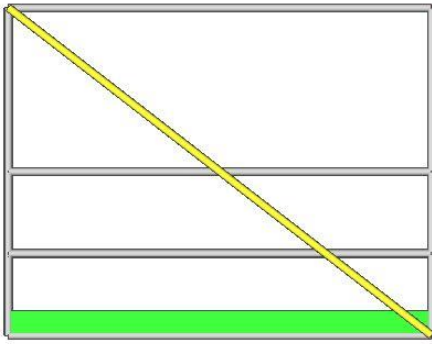

20% of the total pressure is entered on the walls. This equals a total maximal wind pressure of  $0.76 \text{ kN/m}^2 \times 0.2 = 0.152 \text{ kN/m}^2$ .

Code EN 12811-1 §6.2.7.4.1.:

*To make allowance for equipment or materials which are on the working area, a nominal reference area shall be assumed at its level over its full length. This area shall be 200 mm high measured from the level of the working area and includes the height of the toeboard. The loads resulting from the wind pressure on this area shall be assumed to act at the level of the working area.*

In this example, the toeboards are already calculated in the “20% of the total surface”:

In this example the toeboards are 150mm high. The area of EN12811-1; §6.2.7.4.1 is 200mm so it is necessary to calculate with an extra height of 50mm (200mm-50mm) due to equipment of the working area. 50mm high on a total length of 2m (= 2000mm) corresponds to 2.5% (=50/2000).

So the wind pressure is:  $0.152 \text{ kN/m}^2 + (0.025 \times 0,76\text{kN/m}^2) = \mathbf{0.17 \text{ kN/m}^2}$ .

### Note 1

*When inputting netting on the structure the following procedure can be taken into account to calculate the wind pressure on the structure (Netting = 50%):*

- Calculate the wind force
- 50% of the wind will be stopped by the netting and carried by the first columns
- 20% of the other 50% of this wind will be inserted on the first plane
- 20% of the other 50% of this wind will be inserted on the second plane
- ...

### Note 2

*In this paragraph the wind has been calculated as a wind pressure. In EN 12810-1a calculation with wind forces instead of wind pressures. The difference of this method with the EN 1991-1-4 will be discussed in Annex A.*

## Load Case 6: Maximal Wind load Parallel to Facade

In an analogous way, the Maximal Wind load is entered parallel to the facade on the structure.

Also here maximal wind pressures of **0.17kN/m<sup>2</sup>** are entered.

## Load Case 7: Working Wind load Perpendicular to Facade

The code EN12811-1 prescribes that if the scaffolding is into service, it only needs to be loaded with the so-called working wind load.

This working wind load is calculated analogously to the Maximal Wind load on the scaffolding, but a reference wind pressure of 0.2 kN/m<sup>2</sup> is assumed.

The calculation is done analogous to the maximal wind pressure, only the reference wind pressure of 0.429 kN/m<sup>2</sup> (=26,2m/s) from item "Load Case 8" is now replaced by 0.2 kN/m<sup>2</sup>:

EN 12811-1 §6.2.7.4.2:

*A uniformly distributed velocity pressure of 0,2 kN/m<sup>2</sup> shall be taken into account. To make allowance for equipment or materials being on the working area, a nominal reference area as defined in 6.2.7.4.1, but 400 mm high, shall be used in calculating working wind loads.*

$$q_p(z) = c_e(z) \cdot 0,2 \text{ kN} / \text{m}^2 = 1,77 \cdot 0,2 \text{ kN} / \text{m}^2 = 0,354 \text{ kN} / \text{m}^2$$

The toeboards in this example are 150 mm high. In total an extra height of 250 mm (= 400mm – 150mm) is calculated with. This corresponds to 12.5% of the total construction (= 250/2000).

Subsequently, the wind pressure is multiplied by 20% (total surface of the members) and 12.5% (due to accumulation of material).

So the wind pressure is: 0,354 kN/m<sup>2</sup> x (0.2+0,125) = **0,115 kN/m<sup>2</sup>**

## Load Case 8: Working Wind load Parallel to Facade

In an analogous way, the working wind load is entered parallel to the facade on the structure. In this case, the wind pressures are also **0.115 kN/m<sup>2</sup>**.

## Combinations

### Principle of combinations EN 12811-1

Following EN 12811-1, 6.2.9.2 the load cases have to be combined in two different ways: the service condition and the out of service condition

In each individual case the service condition and the out of service condition shall be considered.

a) The service condition consists of:

- 1) The self weight of the scaffold
- 2) Uniformly distributed service load (EN 12811-1, Table 3, q<sub>1</sub>) acting on the working area of the most unfavourable decked level

- 3) 50 % of the load specified in a)2) shall be taken to act on the working area at the next level above or below if a working scaffold has more than one decked level.
- 4) Working wind load
- b) The out of service condition consists of:
- 1) The self weight of the scaffold
  - 2) A percentage of the uniformly distributed service load (EN 12811-1, Table 3,  $q_1$ ) acting on the working area of the most unfavourable decked level. The value depends on the class:
 

Class 1:	0%	(no service load on the working area)
Classes 2 and 3:	25%	(representing some stored materials on the working area)
Classes 4, 5 and 6:	50%	(representing some stored materials on the working area)
  - 3) The maximum wind load

In cases a)2) and b)2), the load shall be taken as zero, if its consideration leads to more favourable results.

### Combinations in SCIA Engineer:

With the principles described earlier in this chapter, the following load cases are made:

#### Combination 1: Out of service, Wind perpendicular

BG1	Self weight
BG2	Self weight toeboards
BG4	Service load max wind
BG5	Maximal wind load perpendicular with facade

#### Combination 2: Out of service, Wind parallel

BG1	Self weight
BG2	Self weight toeboards
BG4	Service load max wind
BG6	Maximal wind load parallel with facade

#### Combination 3: Into service, Wind perpendicular

BG1	Self weight
BG2	Self weight toeboards
BG3	Service load in service
BG7	Working wind load perpendicular with facade

### Combination 4: Into service, Wind parallel

BG1	Self weight
BG2	Self weight toeboards
BG3	Service load in service
BG8	Working wind load parallel with facade

### Coefficients

With the Combinations in Ultimate Limit State, a safety factor  $\gamma_F$  of **1,50** on the load cases is taken, conformable to the code EN 12811 §10.3.2. The safety factor  $\gamma_{M0}$  on the material is **1,10**.

For the serviceability  $\gamma_F$  and  $\gamma_M$  shall be taken as **1,00**.

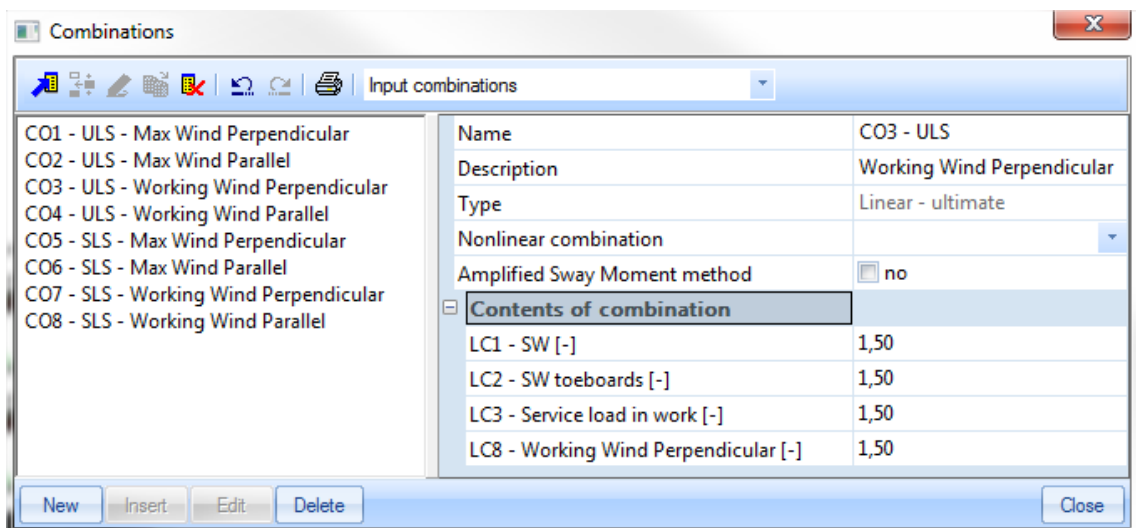

And we can change the safety factor for steel in SCIA Engineer in the National Annex:  
Change  $\gamma_{M0}$  from 1,00 to 1,10

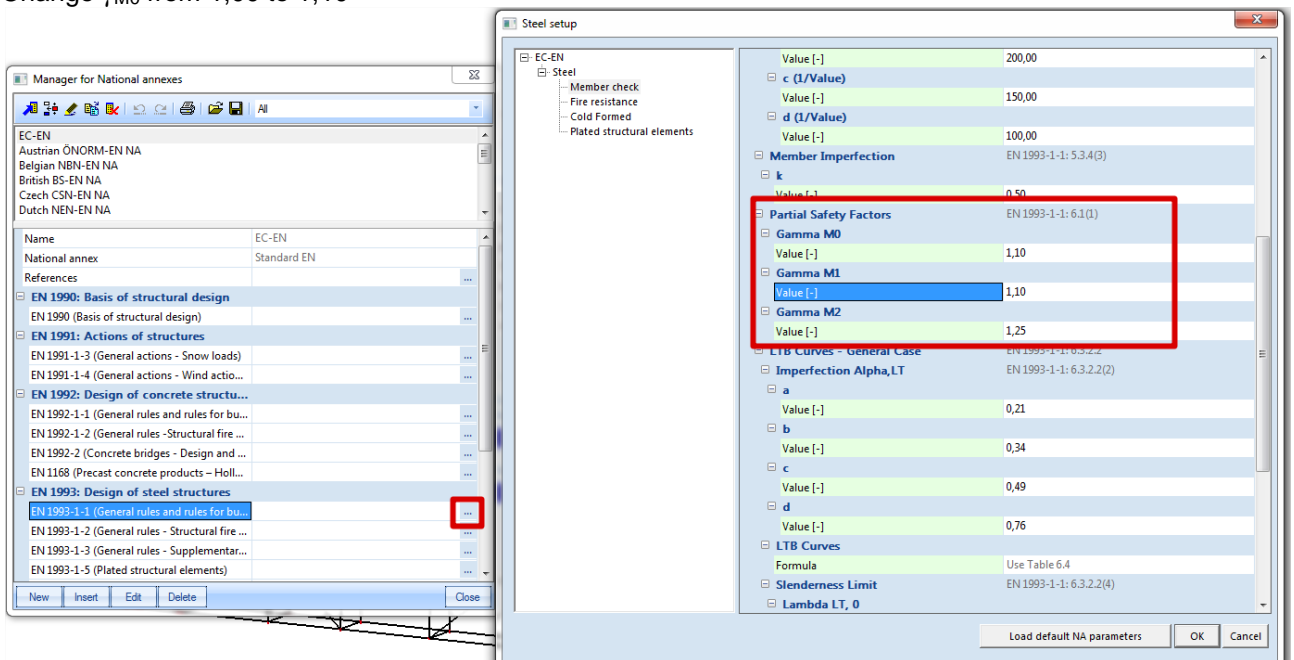

## 4. Results

It is recommended to take a look at the reactions first. This way you can check the accuracy of the imported loads and load combinations. The calculation protocol (in the result dialog) should be reviewed as well.

The bill of material can also be found in the results menu. In this table the total length for each cross section is shown.

With these results, each user can divide the total length of each type of cross section by the length of one member, in order to calculate the total number of ledgers, columns, ... necessary for the construction.

### ➤ Example

Scaffolding.esa

#### 1. Bill of material

Name  
Bill of material

Name	Mass [kg]	Surface [m <sup>2</sup> ]	Volume [m <sup>3</sup> ]
Total results :	3768,4	246,603	3,0933e+00

CSS	Material	Unit mass [kg/m]	Length [m]	Mass [kg]	Surface [m <sup>2</sup> ]	Unit volume mass [kg/m <sup>3</sup> ]	Volume [m <sup>3</sup> ]
Standard - RO48.3X3.2	S 235	3,6	130,000	462,3	19,760	7850,0	5,8890e-02
Ledger - RO48.3X3.2	S 235	3,6	206,330	733,7	31,362	7850,0	9,3468e-02
Guardrail - RO48.3X3.2	S 235	3,6	149,660	532,2	22,748	7850,0	6,7796e-02
Bracing - RO48.3X2.3	S 235	2,6	83,401	217,4	12,677	7850,0	2,7689e-02
FB 0.32 - Rectangle (40; 320)	FB32	8,2	222,300	1822,9	160,056	640,6	2,8454e+00

The results (such as normal force, moment, ...) can be viewed per profile type (columns, bracings, ledgers). That is why it is recommended to put every cross section in different layers. This way it will be easier to review the results per cross section type.

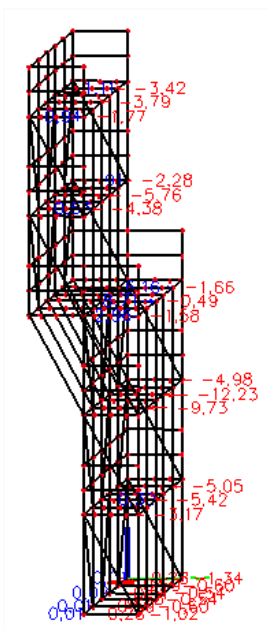

Apart from reviewing the results, the anchorage forces have to be checked as well. These can be found in "Reactions":



## 5. Scaffolding SLS Check – EN 12811-1

The deformation check in SLS is a part of EC3. According to the code EN1281-11 the allowable deformation is  $L/100$ . This limit value is set as follows:

Steel -> Setting => Setting of the Relative Deformation => Bring all values to 100

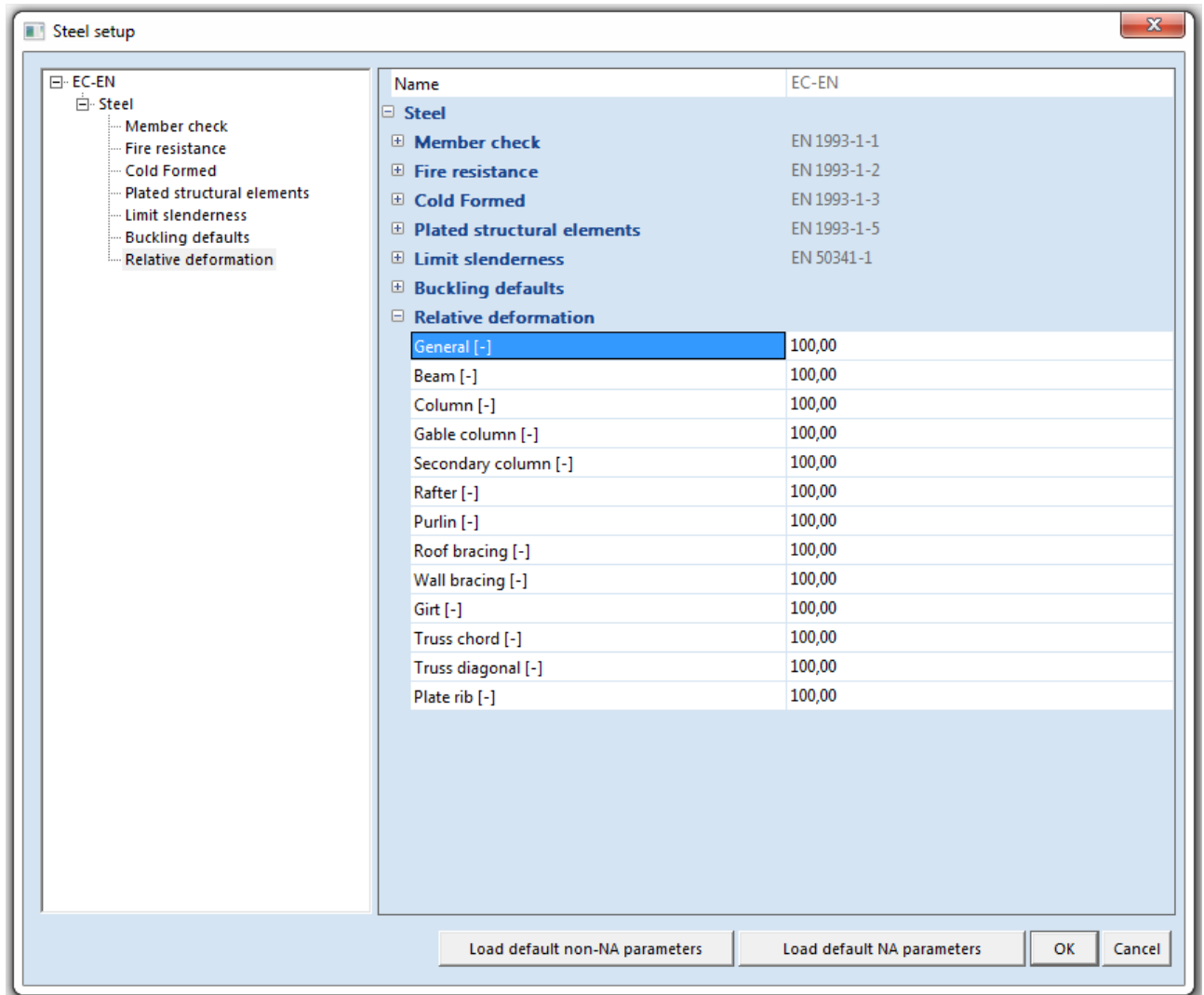

### ➤ SLS check in SCIA Engineer

- Choose for “Relative deformation” in the steel menu and check this for the Class All SLS and for the ledgers
- The maximum check will be found for beam B349: a unity check of 0,24.
- The values of this check are displayed below.

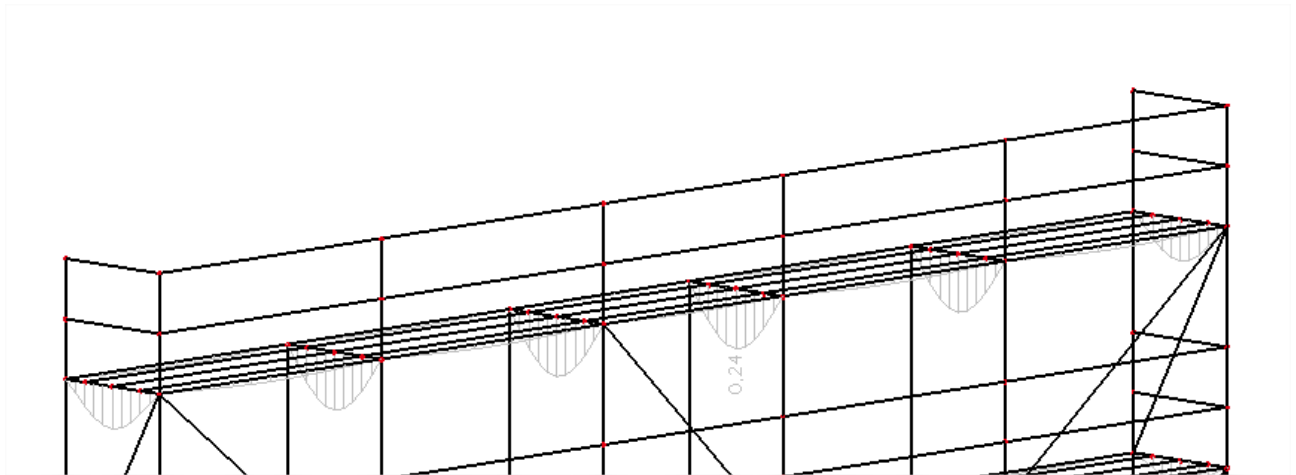

## Relative deformation

Linear calculation, Extreme : Global, System : Principal

Selection : All

Class : All SLS

Cross-section : Ledger - RO48.3X3.2

Member	dx [m]	Case - combination	uy [mm]	Rel uy [1/xx]	uz [mm]	Rel uz [1/xx]	Check uy [-]	Check uz [-]
B171	1,499	CO8 - SLS/2	-0,2	<b>1/10000</b>	-0,4	1/6801	<b>0,01</b>	0,01
B174	1,285	CO8 - SLS/2	<b>0,3</b>	<b>1/7413</b>	-0,8	1/3208	<b>0,01</b>	0,03
B349	0,545	CO7 - SLS/1	0,0	0	<b>-2,7</b>	<b>1/411</b>	0,00	<b>0,24</b>
B110	0,172	CO7 - SLS/1	0,0	1/10000	<b>0,1</b>	1/10000	0,00	0,00
B26	0,818	CO5 - SLS/3	0,0	1/10000	0,1	<b>1/10000</b>	0,00	<b>0,01</b>

## 6. Scaffolding ULS Check – EN 12811-1-1

### General

For a steel check the ULS combinations are used.

If necessary, the buckling settings of the members have to be checked.

It is recommended to deselect the option "Standard unbraced" in the menu "Steel -> Setting -> Setting check steel members" for both directions.

Further settings about the buckling data can be adapted in the property window of every member, by clicking on the three dots behind "Buckling and relative lengths".

After all the settings have been set right, the check can be performed through "Steel -> Check". Also here it is recommended to review the check per profile type.

This is the regular steel check that is displayed, but for scaffolding a supplementary check will be added. This check is performed with the interaction formulae, shown below.

	$\frac{V}{V_{pl,d}} \leq \frac{1}{3}$	$\frac{1}{3} < \frac{V}{V_{pl,d}} \leq 0,9$
$\frac{N}{N_{pl,d}} \leq \frac{1}{10}$	$\frac{M}{M_{pl,d}} \leq 1$	$\frac{M}{M_{pl,d} \cdot \sqrt{1 - \left(\frac{V}{V_{pl,d}}\right)^2}} \leq 1$
$\frac{1}{10} < \frac{N}{N_{pl,d}} \leq 1$	$\frac{M}{M_{pl,d} \cdot \cos\left(\frac{\pi \cdot N}{2N_{pl,d}}\right)} \leq 1$	$\frac{M}{M_{pl,d} \left[ \sqrt{1 - \left(\frac{V}{V_{pl,d}}\right)^2} \cos\left(\frac{\pi \cdot N}{2N_{pl,d} \sqrt{1 - \left(\frac{V}{V_{pl,d}}\right)^2}}\right) \right]} \leq 1$

According to the Eurocode, the check is only prescribed according to the left hand side table

$$\frac{V}{V_{pl,d}} \leq \frac{1}{3}.$$

If this condition is not met, the construction has to be adapted. However, this is a very heavy check, which is why a second column is added in SCIA Engineer, which actually comes from the DIN-code.

## Scaffolding check in SCIA Engineer

Choose for “Scaffolding Check” in the steel code check.

The maximum check will be found for beam B348: a unity check of 0,71.

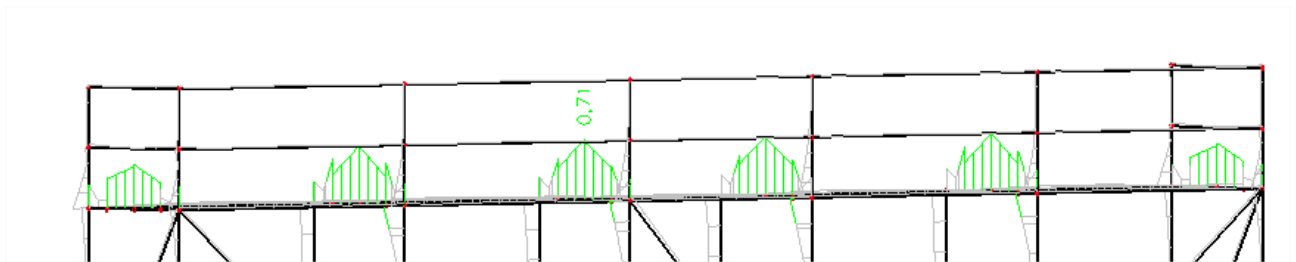

### Check of steel

Linear calculation, Extreme : Global  
Selection : All  
Class : All ULS

EN 1993-1-1 Code Check

EN 12811-1 Scaffolding Check

National annex: Standard EN

Member B348	1,090 m	RO48.3X3.2	S 235	CO3 - ULS/4	0,71 -
-------------	---------	------------	-------	-------------	--------

Partial safety factors	
Gamma M0 for resistance of cross-sections	1,10
Gamma M1 for resistance to instability	1,10
Gamma M2 for resistance of net sections	1,25

Material		
Yield strength fy	235,0	MPa
Ultimate strength fu	360,0	MPa
Fabrication	Rolled	

....SECTION CHECK:....

The critical check is on position 0.545 m

Internal forces	Calculated	Unit
N,Ed	-0,43	kN
Vy,Ed	-0,04	kN
Vz,Ed	-1,32	kN
T,Ed	0,00	kNm
My,Ed	0,91	kNm
Mz,Ed	0,01	kNm

#### Scaffolding check for tubular members

According to EN 12811-1 & DIN 4420 Teil 1 art. 5.4.7.4 and table 7

Table of values		
Npl.d	96,78	kN
Vpl.d	35,57	kN
Mpl.d	1,28	kNm
Unity check N	0,00	
Unity check V	0,04	
Unity check M	0,71	
Unity check Interaction	0,71	
Unity check Max	0,71	-

Note: As specified in EN 12810 & 12811 the scaffolding check for tubular members assumes the use of a 2nd order analysis including imperfections. Please make sure the proper settings are set or use the default EN 1993-1-1 check instead.

The member satisfies the section check.

SCIA Engineer will show you directly the scaffolding check, when choosing for the Eurocode check for circular hollow sections, because we have activated the “Scaffolding” functionality in the beginning of the project. If you don’t want to see the scaffolding check, but the general Eurocode check (EN 1993-1-1), you can uncheck this option in the Steel Setup:

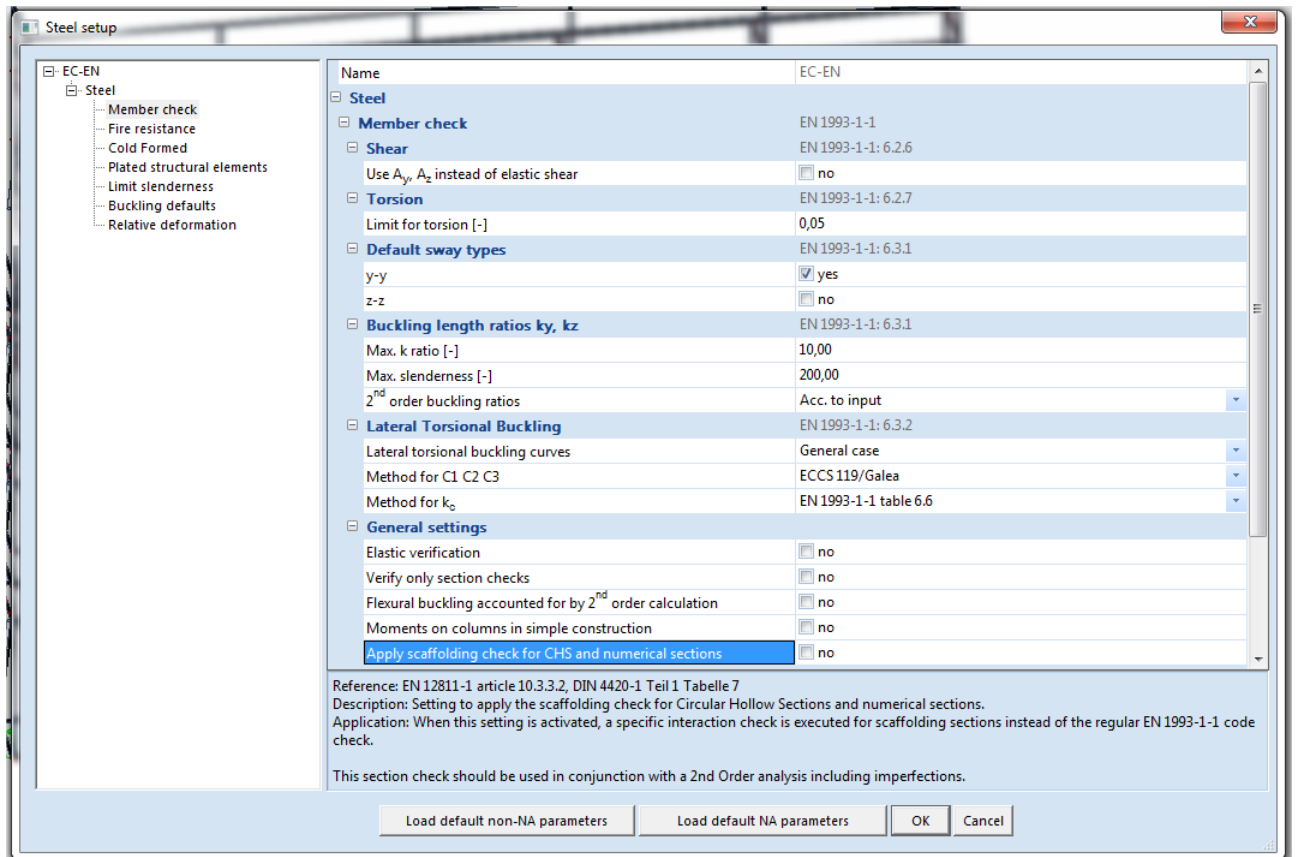

## 7. Non-Linear Combinations

### Overview

Global analysis aims at determining the distribution of the internal forces and moments and the corresponding displacements in a structure subjected to a specified loading.

The first important distinction that can be made between the methods of analysis is the one that separates elastic and plastic methods. Plastic analysis is subjected to some restrictions.

Another important distinction is between the methods, which make allowance for, and those, which neglect the effects of the actual, displaced configuration of the structure. They are referred to respectively as **second-order theory** and **first-order theory** based methods.

The second-order theory can be adopted in all cases, while first-order theory may be used only when the displacement effects on the structural behavior are negligible.

The second-order effects are made up of a local or member second-order effects, referred to as the  $P-\delta$  effect, and a global second-order effect, referred to as the  $P-\Delta$  effect.

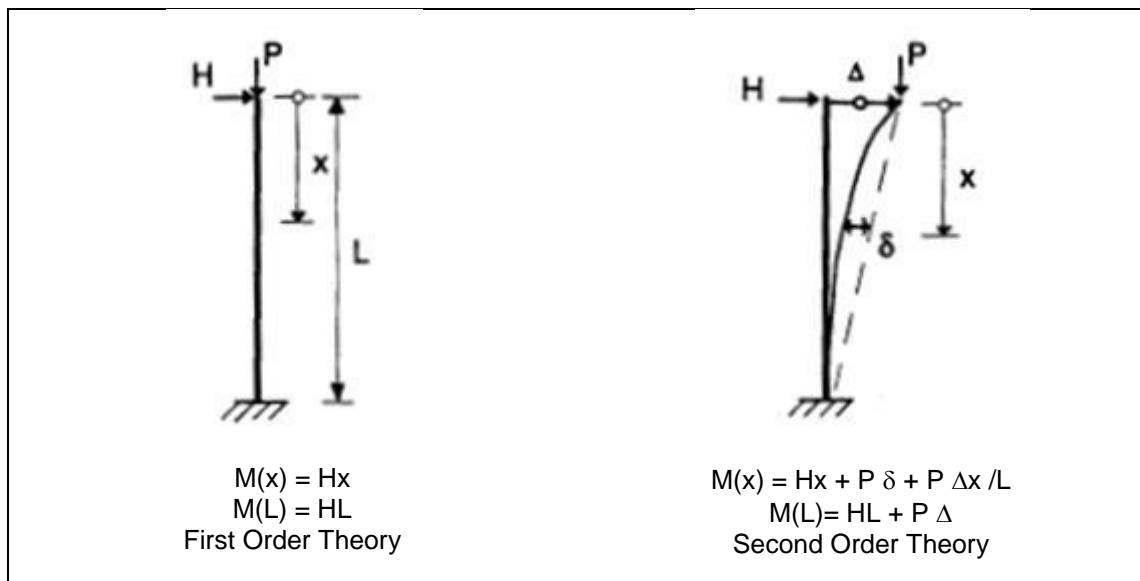

On the next page an overview of the global analysis following the EN 1993-1-1, chapter 5, will be given:

- All the rules in this overview are given in the EN 1993-1-1 art. 5. For each step the rule will be indicated. The first rule ( $\alpha_{cr} \geq 10$ ) will be explained in EN 1993-1-1 **art. 5.2.1(3)**.
- In this overview 3 paths are defined:
  - Path 1: In this path a first order calculation will be executed
  - Path 2: In this path a second order calculation will be executed with global (and bow) imperfections.
  - Path 3: In this path a second order calculation will be executed with the buckling shape of the construction as imperfection.
- The calculation will become more precise when choosing for a higher path.
- The lower paths will result in a faster calculation, because a first order calculation can be executed without iterations, but this first-order theory may be used only when the displacement effects on the structural behavior are negligible.
- In the next paragraphs the rules in this overview will be explained.

To take into account all non-linearity's in the model, non-linear load combinations are made.

Furthermore, the following applies according to the code **EN 12810-2**:

Design stage	Path 1		Path 2	
	Modular and frame systems		Frame systems only	
1	Tests for configurations, connection devices and components			
2 / 3	Calculation for each system configuration of the standard set			
2			Determination of $\alpha_{cr}$	
			Continuation of path 2 only if $\alpha_{cr} \geq 2$ ; if $\alpha_{cr} < 2$ change to path 1	
3	3a	Analysis of the structure to determine the distribution of forces and moments using Second order theory		First order theory with amplification factors on the basis of $\alpha_{cr}$
	3b	Analysis of the individual components and connection to verify that the resistance is adequate		
4	One test on a representative section of a system configuration			
	Type 1	For the verification of significant load displacement behaviour		Type 2 For the verification of $\alpha_{cr}$

$\alpha_{cr}$  is the lowest elastic buckling load factor to be applied to the design loads

We can conclude that a second order calculation is always recommended. This second order calculation implies to take the local and global imperfections into account, so non-linear combinations have to be used. This principle is also shown in the following flow chart of the EN 12810-2:

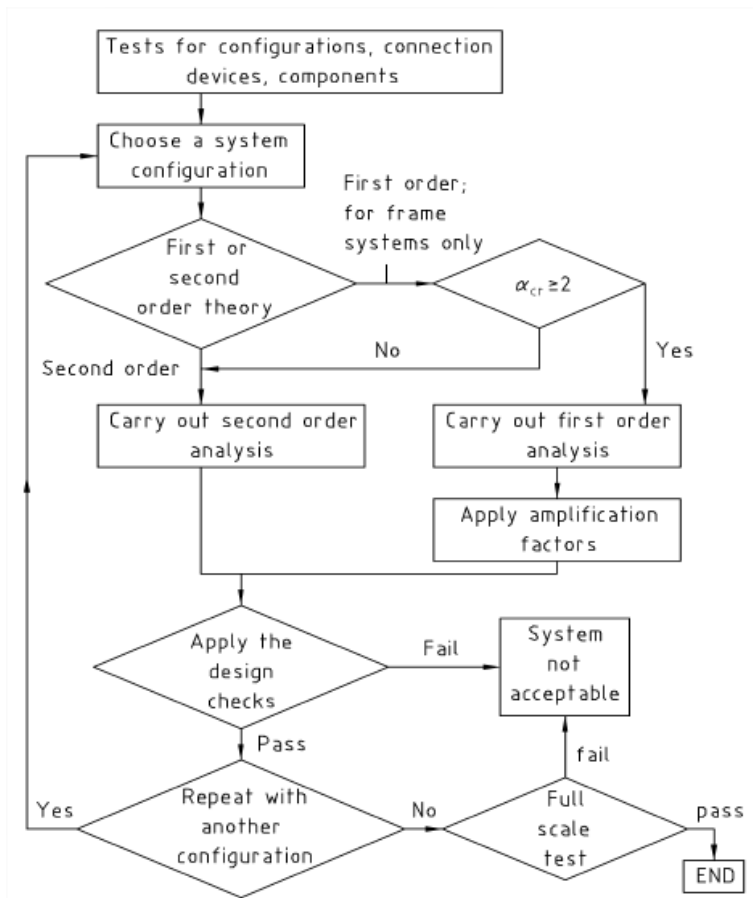
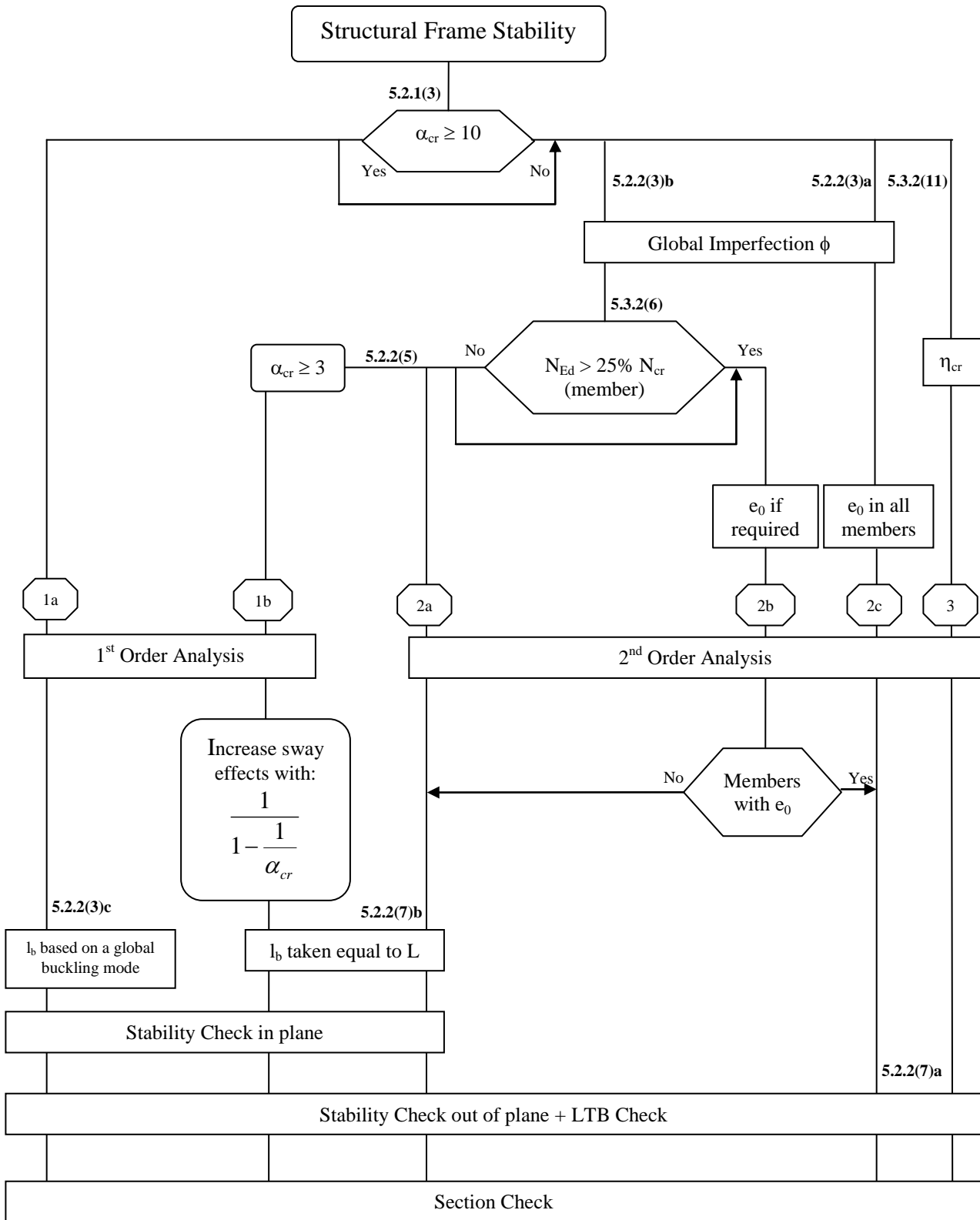

Figure 1 — Flow diagram of the stages of the structural design

Non linear combinations are made as described in the previous chapter.

The general procedure for the new EC-EN is shown in the following diagram.



With:  $\eta_{cr}$  Elastic critical buckling mode.  
 L Member system length  
 $l_b$  Buckling Length

Path 1a specifies the so called Equivalent Column Method. In step 1b and 2a “ $l_b$  may be taken equal to L”. This is according to EC-EN so the user does not have to calculate the buckling factor =1. In further analysis a buckling factor smaller than 1 may be justified.



## Alpha critical

The calculation of alpha critical is done by a stability calculation in SCIA Engineer. For this calculation a Professional or an Expert edition is necessary. The stability calculation has been inputted in module esas.13.

According to the EN 1993-1-1, 1<sup>st</sup> Order analysis may be used for a structure, if the increase of the relevant internal forces or moments or any other change of structural behaviour caused by deformations can be neglected. This condition may be assumed to be fulfilled, if the following criterion is satisfied:

$$\alpha_{cr} = \frac{F_{cr}}{F_{Ed}} \geq 10 \text{ for elastic analysis}$$

With:  $\alpha_{cr}$ : the factor by which the design loading has to be increased to cause elastic instability in a global mode.  
 $F_{Ed}$ : the design loading on the structure.  
 $F_{cr}$ : the elastic critical buckling load for global instability, based on initial elastic stiffnesses.

If  $\alpha_{cr}$  has a value lower than 10, a 2<sup>nd</sup> Order calculation needs to be executed. Depending on the type of analysis, both Global and Local imperfections need to be considered.

EN1993-1-1 prescribes that 2<sup>nd</sup> Order effects and imperfections may be accounted for both by the global analysis or partially by the global analysis and partially through individual stability checks of members.

## Global frame imperfection $\phi$

The global frame imperfection will be inputted for the whole structure by an imperfection value  $\phi$ . This value can be calculated with the following formula (EN 1993-1-1 art. 5.3.2(3)a):

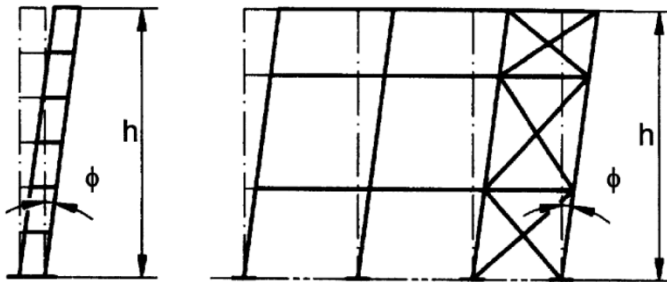

- $\phi = \frac{1}{200} \cdot \alpha_h \cdot \alpha_m$
- $\alpha_h = \frac{2}{\sqrt{h}}$  but  $\frac{2}{3} \leq \alpha_h \leq 1,0$
- $\alpha_m = \sqrt{0,5 \left(1 + \frac{1}{m}\right)}$

With: h The height of the structure in meters

- m The number of columns in a row including only those columns which carry a vertical load  $N_{Ed}$  not less than 50% of the average value of the vertical load per column in the plane considered.

These inclination functions are entered through “Main -> Library -> Structure, Analysis -> Initial deformations”:

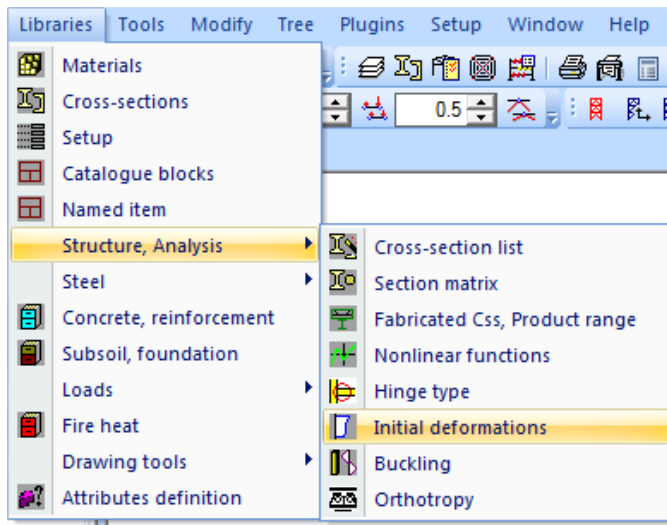

The Type is chosen as “According to code”, with a standard imperfection of 1/200.

The height of the construction is 11m for both inclination functions.

There are 6 columns in the X-direction, therefore the number of columns in this direction has been inputted as “6”.

There are 2 columns in the Y-direction, therefore the number of columns in this direction has been inputted as “2”.

The inclination function for the x-direction (Def\_X) in SCIA Engineer is displayed below:

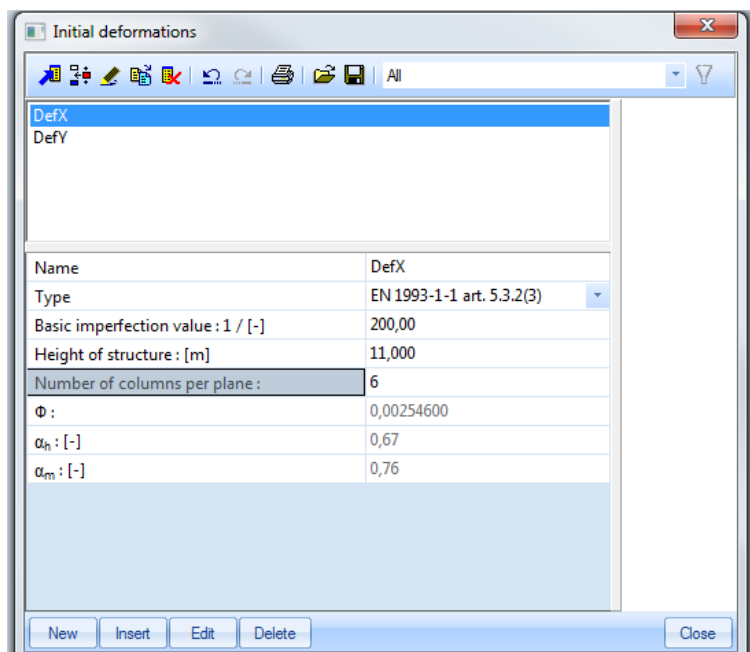

All combinations are entered four times, once with the inclination according to positive x and once according to positive y and negative x and negative y:

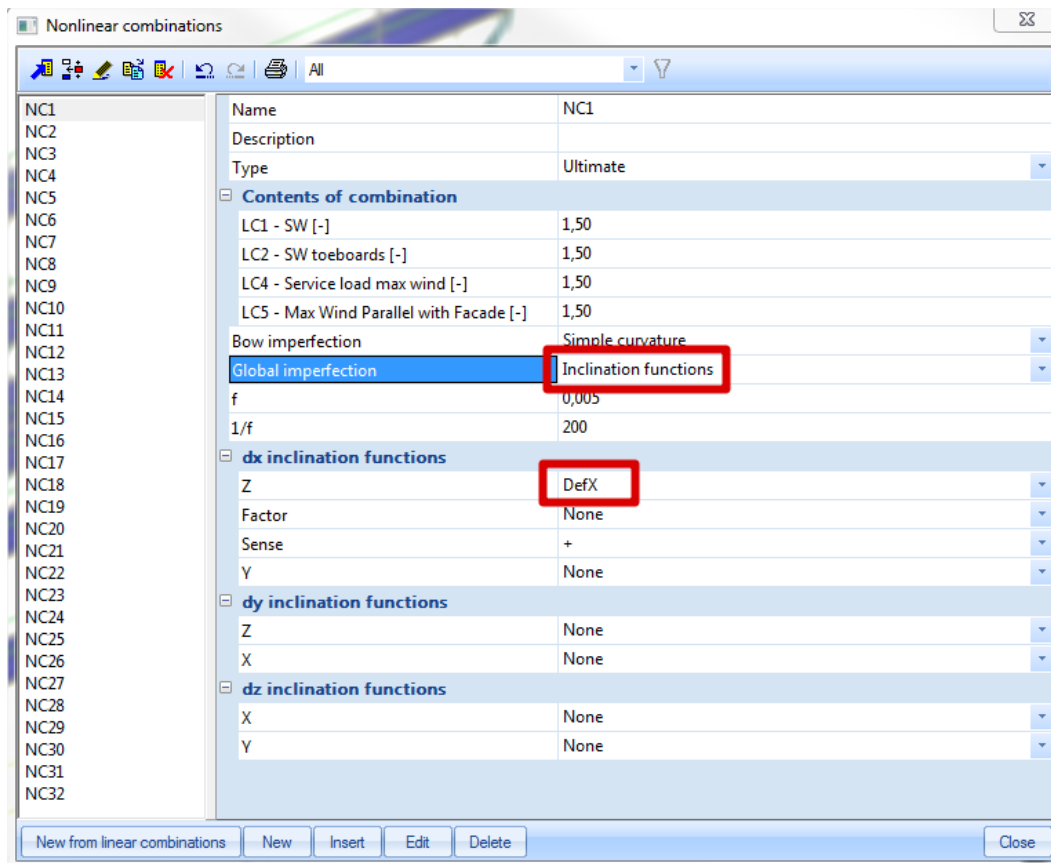

### Initial bow imperfection $e_0$

The initial bow imperfection is given by:

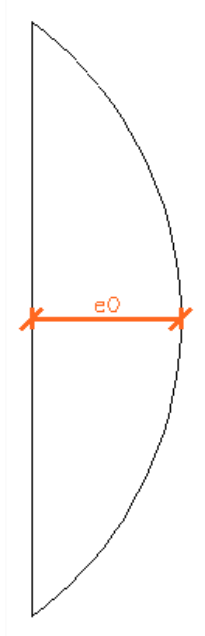

Buckling curve acc. to Table 6.1	elastic analysis	plastic analysis
	$e_0 / L$	$e_0 / L$
$a_0$	1 / 350	1 / 300
a	1 / 300	1 / 250
b	1 / 250	1 / 200
c	1 / 200	1 / 150
d	1 / 150	1 / 100

Where L is the member length.

The buckling curve used for calculation of the imperfection is the curve inputted in the cross-section library. For standard sections, the curve according to the code is automatically used, for non-standard cross sections (as general cross sections) the user needs to input the buckling curve manually.

Where L is the member length.

The bow imperfection has to be applied when the normal force  $N_{Ed}$  in a member is higher than 25% of the member's critical buckling load  $N_{cr}$ .

SCIA Engineer can calculate the bow imperfection according to the code automatically for all needed members. But in a scaffolding structure all profiles have the same buckling curve and thus the same bow imperfection. This bow imperfection is inputted as "simple curvature": the same curvature for all members.

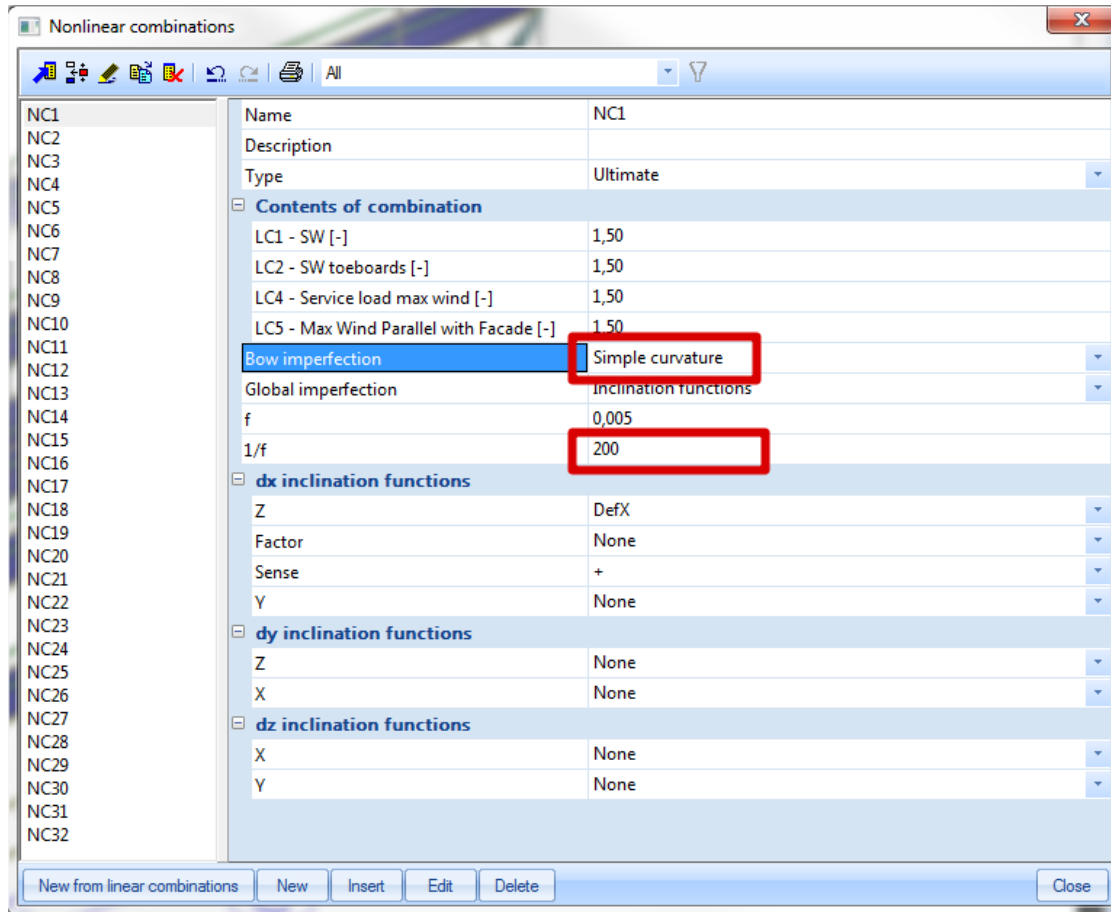

## 8. The second order calculation

### Timoshenko

The first method is the so called **Timoshenko** method (Th.II.O) which is based on the exact Timoshenko solution for members with known normal force. It is a 2<sup>nd</sup> order theory with equilibrium on the deformed structure which assumes small displacements, small rotations and small strains.

When the normal force in a member is smaller than the critical buckling load, this method is very solid. The axial force is assumed constant during the deformation. Therefore, the method is applicable when the normal forces (or membrane forces) do not alter substantially after the first iteration. This is true mainly for frames, buildings, etc. for which the method is the most effective option.

The influence of the normal force on the bending stiffness and the additional moments caused by the lateral displacements of the structure (the P-Δ effect) are taken into account in this method.

This principle is illustrated in the following figure.

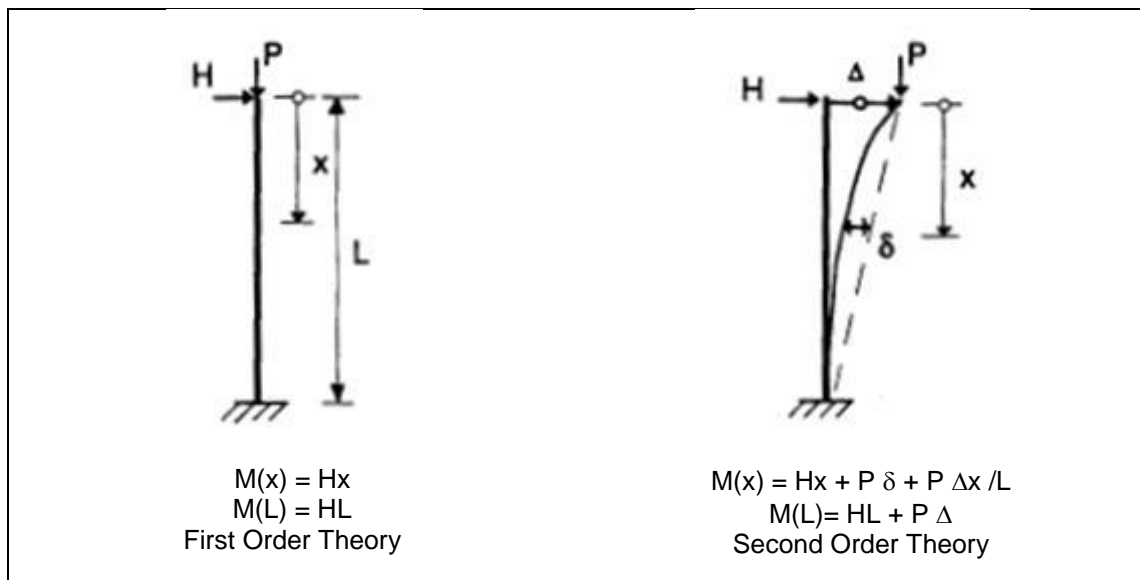

The local P-δ effect will be regarded further in this course.

If the members of the structure are not in contact with subsoil and do not form ribs of shells, the finite element mesh of the members must not be refined.

The method needs only two steps, which leads to a great efficiency. In the first step, the axial forces are solved. In the second step, the determined axial forces are used for Timoshenko's exact solution. The original solution was generalised in SCIA Engineer to allow taking into account shear deformations.

The applied technique is the so called 'total force method' or 'substitution method'. In each iteration step, the total stiffness of the structure is adapted and the structure is re-calculated until convergence. This technique is illustrated in the following diagram.

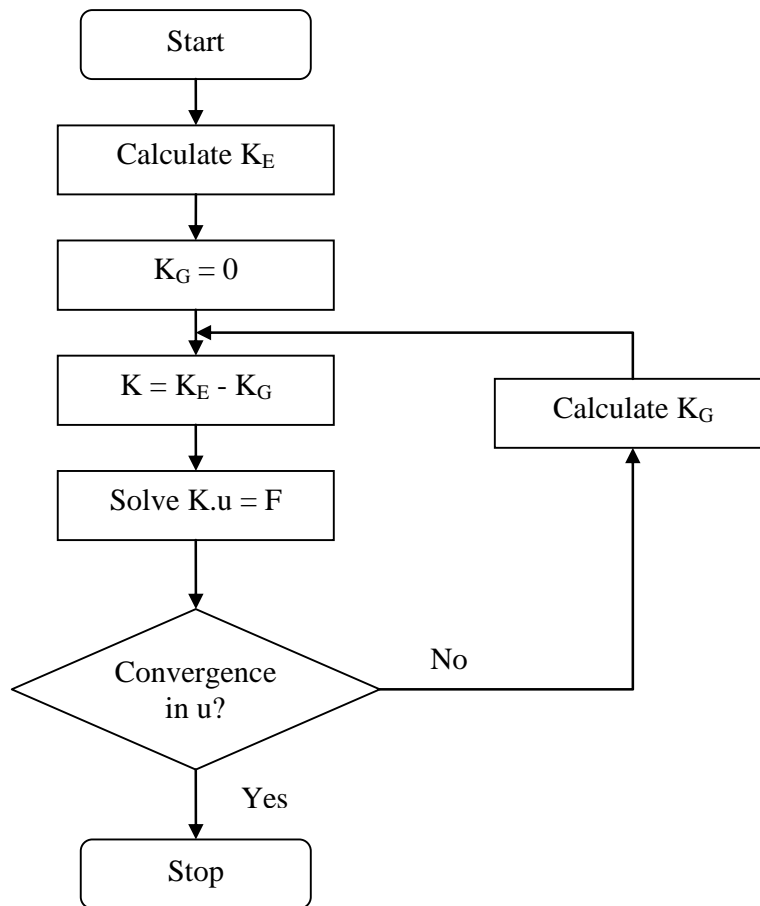

In this figure, the stiffness  $K$  is divided in the elastic stiffness  $K_E$  and the geometrical stiffness  $K_G$ . The geometrical stiffness reflects the effect of axial forces in beams and slabs. The symbol  $\mathbf{u}$  depicts the displacements and  $\mathbf{F}$  is the force matrix.

The criterion for convergence is defined as follows:

$$\frac{\sum(u_{x,i}^2 + u_{y,i}^2 + u_{z,i}^2) - \sum(u_{x,i-1}^2 + u_{y,i-1}^2 + u_{z,i-1}^2)}{\sum(u_{x,i}^2 + u_{y,i}^2 + u_{z,i}^2)} \leq 0,005 / (\text{precision ratio})$$

With:

$u_{x,i}$	The displacement in direction x for iteration i.
$u_{y,i}$	The displacement in direction y for iteration i.
$u_{z,i}$	The displacement in direction z for iteration i.

This convergence precision (Precision ratio) can be adapted in the solver setup:

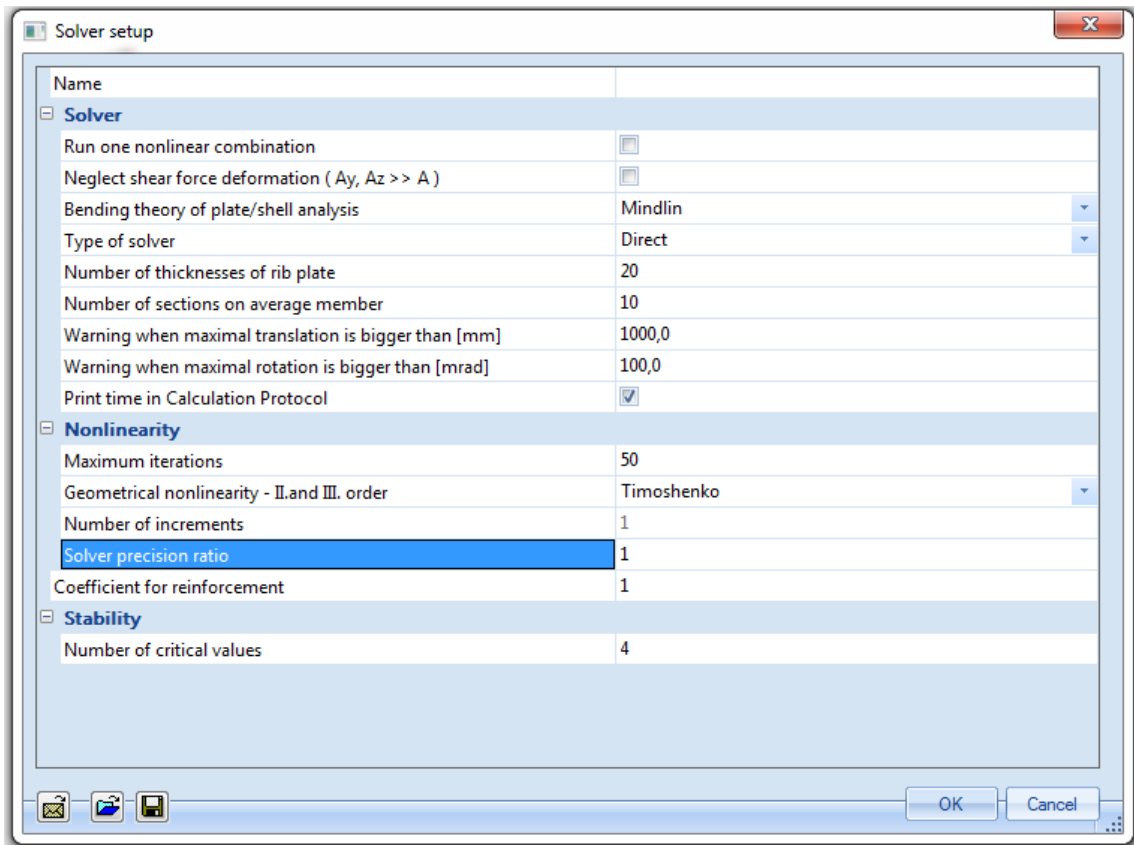

The choice of the Timoshenko Method and the maximal amount of iterations can be specified through **Calculation, Mesh > Solver Setup**.

## Newton Raphson

The second method is the so called **Newton-Raphson** method (Th.III.O) which is based on the Newton-Raphson method for the solution of non-linear equations.

This method is a more general applicable method which is very solid for most types of problems. It can be used for very large deformations and rotations; however, as specified the limitation of small strains is still applicable.

Mathematically, the method is based on a step-by-step augmentation of the load. This incremental method is illustrated on the following diagram:

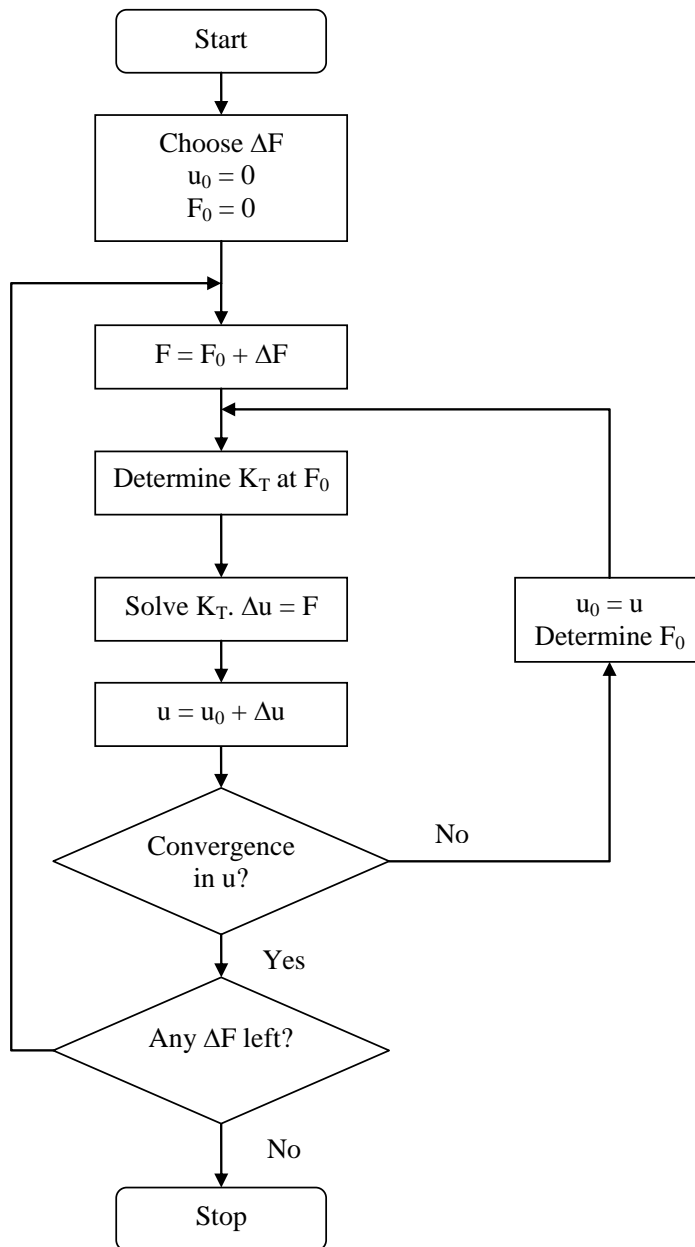

In this figure, the tangential stiffness  $K_T$  is used. The symbol  $u$  depicts the displacements and  $F$  is the force matrix.

The original Newton-Raphson method changes the tangential stiffness in each iteration. There are also adapted procedures which keep the stiffness constant in certain zones during for example one increment. SCIA ENGINEER uses the original method.

As a limitation, the rotation achieved in one increment should not exceed  $5^\circ$ .

The accuracy of the method can be increased through refinement of the finite element mesh and by increasing the number of increments. By default, when the Newton-Raphson method is used, the **Number of increments** is set to **5** and the number of **1D elements** is set to **4** in the mesh setup. In the Mesh setup we also advise to deactivate the option "Generation of nodes in connections of beam elements".



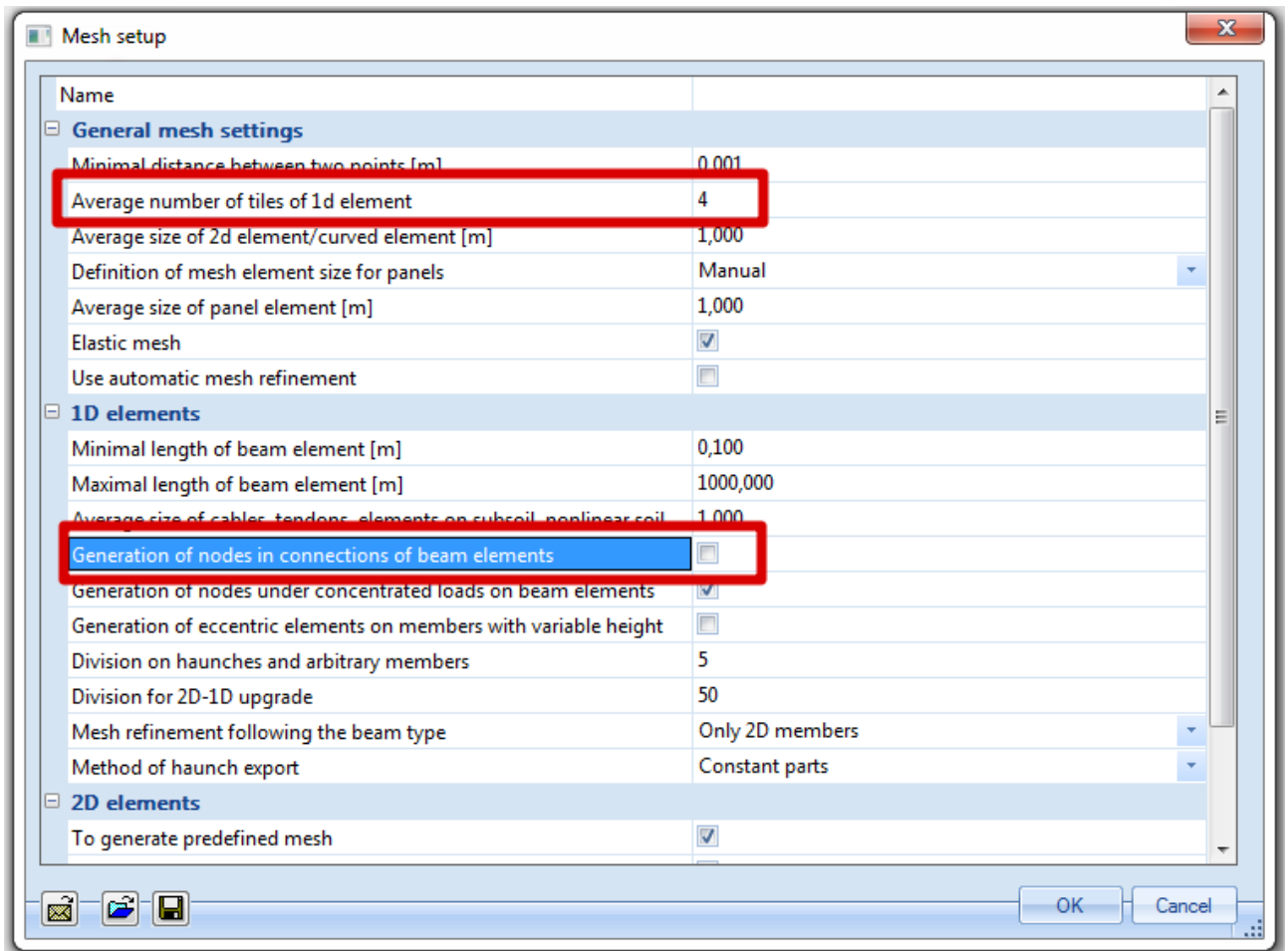

When this option is activated, beams will be connected by the nodes they are going through. But when 4 nodes are inputted on the beams, it could happen that a node has been inputted in the middle of a diagonal and another diagonal is crossing this one in the program and now they are connected. To avoid unwanted connections, we advice to uncheck this option.

In some cases, a high number of increments may even solve problems that tend to a singular solution which is typical for the analysis of post-critical states. However, in most cases, such a state is characterized by extreme deformations, which is not interesting for design purposes.

The choice of the Newton-Raphson Method, the amount of increments and the maximal amount of iterations can be specified through **Calculation, Mesh > Solver Setup**.

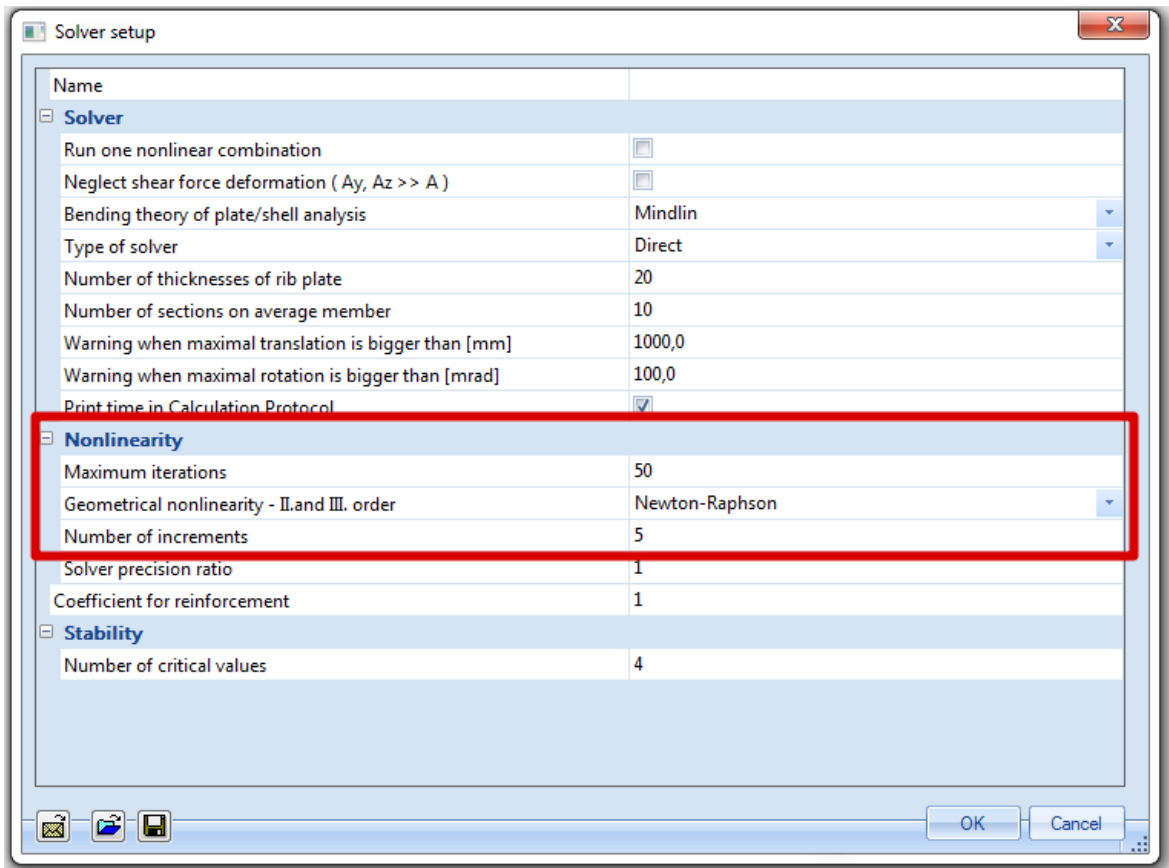

As specified, the Newton-Raphson method can be applied in nearly all cases. It may, however fail in the vicinity of inflexion points of the loading diagram. To avoid this, a specific method has been implemented in SCIA Engineer: the **Modified Newton-Raphson** method.

Also when the Newton-Raphson method is failing, there is the possibility of the method of Picard.

This method follows the same principles as the default method but will automatically refine the number of increments when a critical point is reached. This method is used for the Non-Linear Stability calculation and will be looked upon in Chapter 7.

In general, for a primary calculation the Timoshenko method is used since it provides a quicker solution than Newton-Raphson due to the fact Timoshenko does not use increments. When Timoshenko does not provide a solution, Newton-Raphson can be applied.

## 9. Stability

### Linear Stability

During a linear stability calculation, the following assumptions are used:

- Physical Linearity.
- The elements are taken as ideally straight and have no imperfections.
- The loads are guided to the mesh nodes, it is thus mandatory to refine the finite element mesh in order to obtain precise results.
- The loading is static.
- The critical load coefficient is, per mode, the same for the entire structure.
- Between the mesh nodes, the axial forces and moments are taken as constant.

The equilibrium equation can be written as follows:

$$[K_E - K_G] \cdot u = F$$

The symbol  $\mathbf{u}$  depicts the displacements and  $\mathbf{F}$  is the force matrix.

As specified in the theory of the Timoshenko method, the stiffness  $\mathbf{K}$  is divided in the elastic stiffness  $\mathbf{K}_E$  and the geometrical stiffness  $\mathbf{K}_G$ . The geometrical stiffness reflects the effect of axial forces in beams and slabs.

The basic assumption is that the elements of the matrix  $\mathbf{K}_G$  are linear functions of the axial forces in the members. This means that the matrix  $\mathbf{K}_G$  corresponding to a  $\lambda^{\text{th}}$  multiple of axial forces in the structure is the  $\lambda^{\text{th}}$  multiple of the original matrix  $\mathbf{K}_G$ .

The aim of the buckling calculation is to find such a multiple  $\lambda$  for which the structure loses stability. Such a state happens when the following equation has a non-zero solution:

$$[K_E - \lambda \cdot K_G] \cdot u = 0$$

In other words, such a value for  $\lambda$  should be found for which the determinant of the total stiffness matrix is equal to zero:

$$K_E - \lambda \cdot K_G = 0$$

Similar to the natural vibration analysis, the subspace iteration method is used to solve this eigenmode problem. As for a dynamic analysis, the result is a series of **critical load coefficients**  $\lambda$  with corresponding eigenmodes.

To perform a Stability calculation, the functionality **Stability** must be activated.

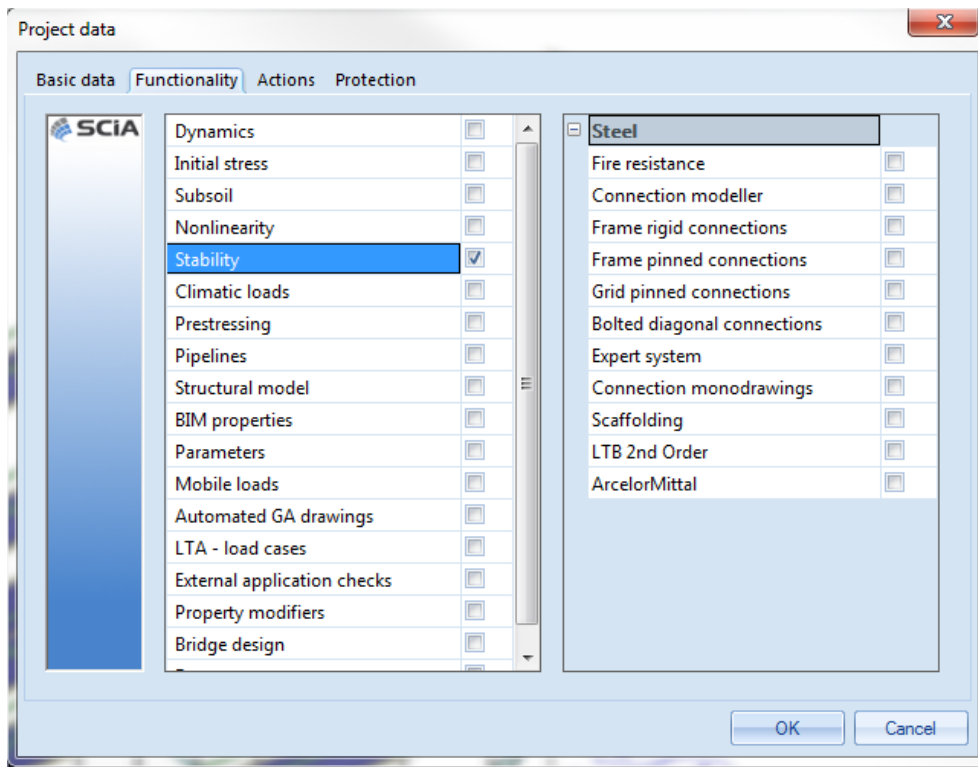

In the results menu, the  $\lambda$  values can be found under the caption  Critical load coefficients  
The number of critical coefficients to be calculated per stability combination can be specified under **Setup > Solver**.

**Note:**

- 
- The first eigenmode is usually the most important and corresponds to the lowest critical load coefficient. A possible collapse of the structure usually happens for this first mode.
  - The structure becomes unstable for the chosen combination when the loading reaches a value equal to the current loading multiplied with the critical load factor.
  - A critical load factor smaller than 1 signifies that the structure is unstable for the given loading.
  - Since the calculation searches for eigen values which are close to zero, the calculated  $\lambda$  values can be both positive or negative.  
A negative critical load factor signifies a tensile load. The loading must thus be inversed for buckling to occur (which can for example be the case with wind loads).
  - The eigenmodes (buckling shapes) are dimensionless. Only the relative values of the deformations are of importance, the absolute values have no meaning.
  - For shell elements the axial force is not considered in one direction only. The shell element can be in compression in one direction and simultaneously in tension in the perpendicular direction. Consequently, the element tends to buckle in one direction but is being 'stiffened' in the other direction. This is the reason for significant post-critical bearing capacity of such structures.
  - Initial Stress is the only local non-linearity taken into account in a Linear Stability Calculation.
  - It is important to keep in mind that a Stability Calculation only examines the theoretical buckling behaviour of the structure. It is thus still required to perform a Steel Code Check to take into account Lateral Torsional Buckling, Section Checks, Combined Axial Force and Bending, ...
-

## Manual calculation of $K_G$

The principle of a stability calculation and the meaning of the matrix  $K_G$  will be explained with a simple example:

Suppose the next situation:

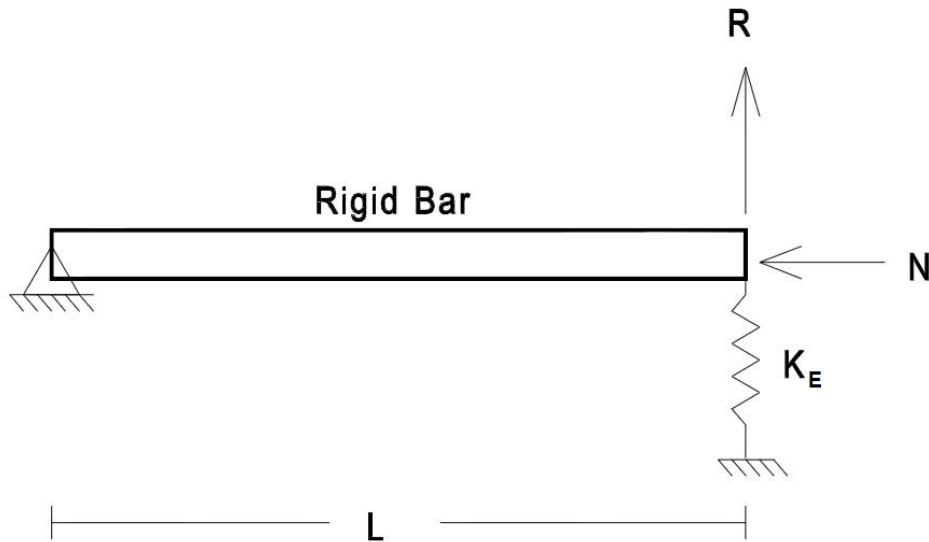

This beam with length  $L$  has a pinned support at the left and a flexible spring support at the right with rigidity:  $K_E$ .

Two point loads are inputed on the beam: a vertical  $R$  and a compression force  $N$ .

Standard analysis says that  $R$  and  $N$  are independent (in the un-deformed configuration) and the stiffness relationship is:

$$K_E \cdot r = R$$

With  $r$  the vertical translation of the right point of the beam.

But, if the structure is allowed to deform, we can calculate equilibrium in the deformed configuration as shown below:

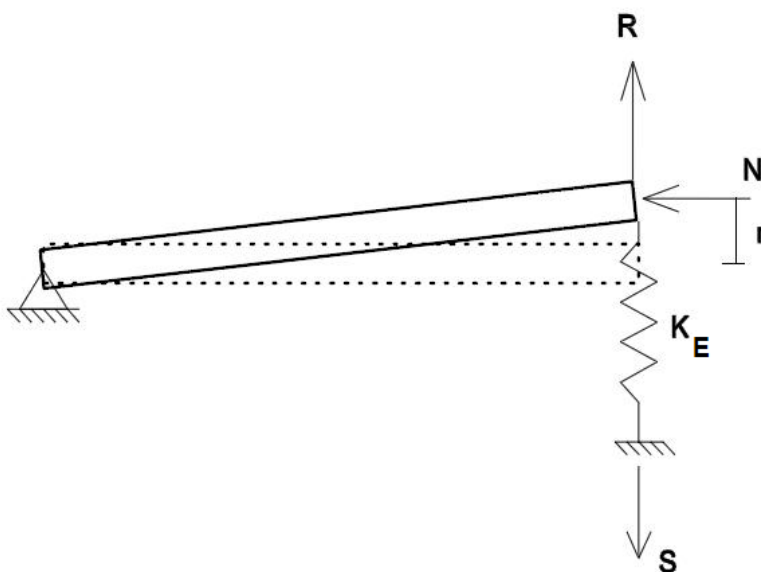

Summing moments about the pinned end we get:

$$R \cdot L + N \cdot r = S \cdot L$$

The equation for the response of the spring is:  $K_E \cdot r = S$

Substituting S we get:

$$R \cdot L + N \cdot r = (K_E \cdot r) \cdot L$$

Dividing by L:

$$R + \frac{N}{L} \cdot r = K_E \cdot r$$

And grouping terms we have:

$$R = \left( K_E - \frac{N}{L} \right) \cdot r$$

This can further be re-written if we define the geometric stiffness as:

$$K_G = \frac{N}{L}$$

giving the final form as:

$$R = (K_E - K_G) \cdot r$$

Of:  $[K_E - K_G] \cdot u = F$

When the normal force **N** is multiplied with a factor  $\alpha_{cr}$  so that the total rigidity becomes zero:

$$K_E - \frac{\alpha_{cr} \cdot N}{L} = 0$$

The structure will buckle and become “unstable”.

## Buckling Shape

As an alternative to Global and Local imperfections, paragraph **13. Non linear combinations** allows the use of a buckling shape as a unique imperfection.

To input geometrical imperfections, the functionality **Nonlinearity > Initial deformations and curvature** and **Stability** must be activated.

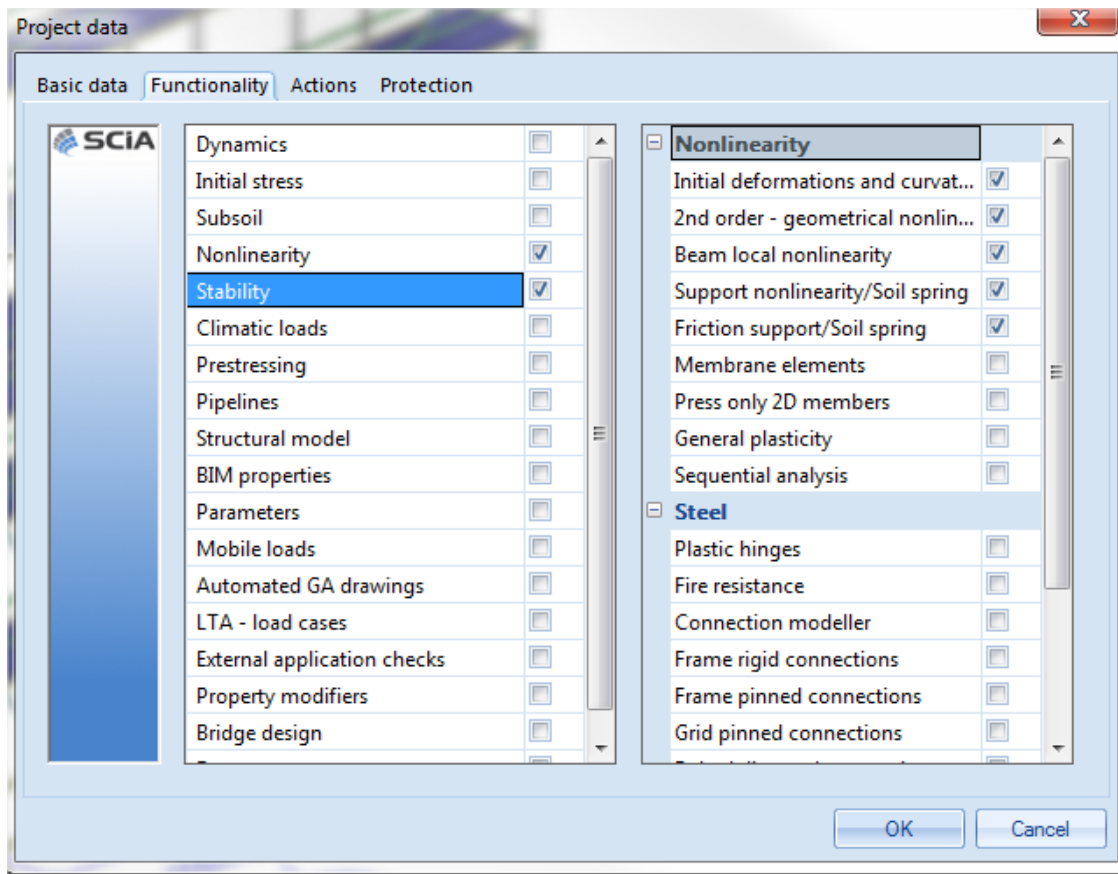

The calculation of the buckling shape through a stability calculation will be looked upon in Chapter 7.

Since the buckling shape is dimensionless, Eurocode gives the formula to calculate the amplitude  $\eta_{init}$  of the imperfection. In Ref.[29] examples are given to illustrate this method. In this reference, the amplitude is given as follows:

$$\eta_{init} = e_0 \cdot \frac{N_{cr}}{E \cdot I_y \cdot \eta_{cr,max}''} \cdot \eta_{cr}$$

$$e_0 = \alpha \cdot (\bar{\lambda} - 0,2) \cdot \frac{M_{Rk}}{N_{Rk}} \cdot \frac{1 - \chi \cdot (\bar{\lambda})^2}{1 - \chi \cdot (\bar{\lambda})^2} \quad \text{for} \quad \bar{\lambda} > 0,2$$

With: 
$$\bar{\lambda} = \sqrt{N_{Rk} / N_{cr}}$$

$\alpha$  = The imperfection factor for the relevant buckling curve.

$\chi$  = The reduction factor for the relevant buckling curve, depending on the relevant cross-section.

$N_{Rk}$  = The characteristic resistance to normal force of the critical cross-section, i.e.  $N_{pl,Rk}$ .

$N_{cr}$  = Elastic critical buckling load.

$M_{Rk}$  = The characteristic moment resistance of the critical cross-section, i.e.  $M_{el,Rk}$  or  $M_{el,Rk}$  as relevant.

$\eta_{cr}$  = Shape of the elastic critical buckling mode.

$\eta_{cr,max}''$  = Maximal second derivative of the elastic critical buckling mode.

The value of  $\eta_{init}$  can then be entered in the field **Max deformation**.

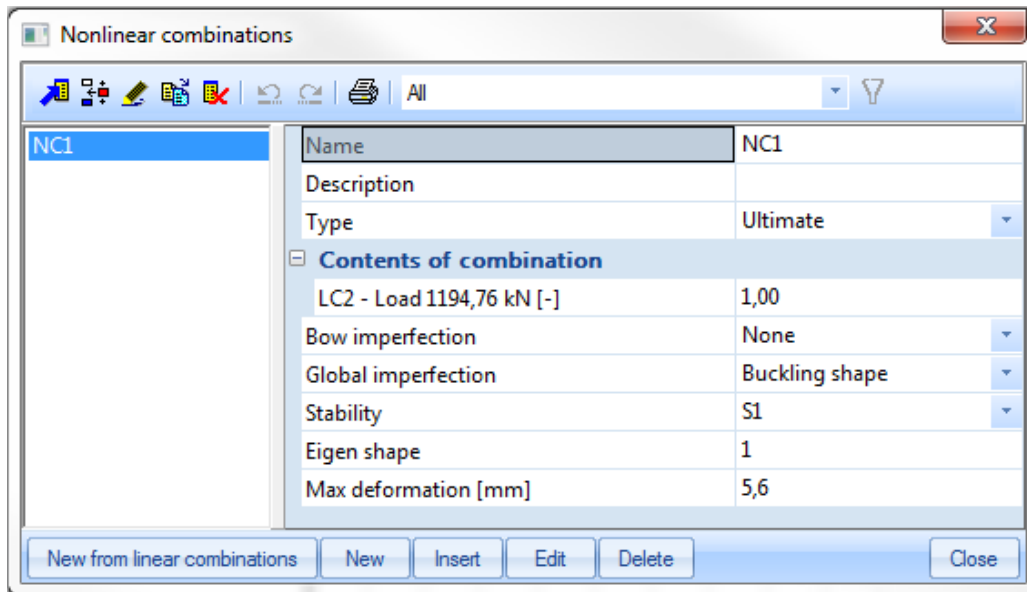

### ➤ Example Stability\_Imprecision.esa

In Chapter 6, the use of the buckling shape as imperfection according to EC3 was discussed. In this example, the procedure is illustrated for a column.

The column has a cross-section of type **RO48,3x3,2**, is fabricated from **S235** and has the following relevant properties:

$$\begin{array}{lll}
 E = 210.000 \text{ N/mm}^2 & f_y = 235 \text{ N/mm}^2 & \gamma_{M1} = 1.00 \\
 L = 2000 \text{ mm} & A = 453 \text{ mm}^2 & \\
 I_y = 116000 \text{ mm}^4 & W_{pl,y} = 6508,8 \text{ mm}^3 & 
 \end{array}$$

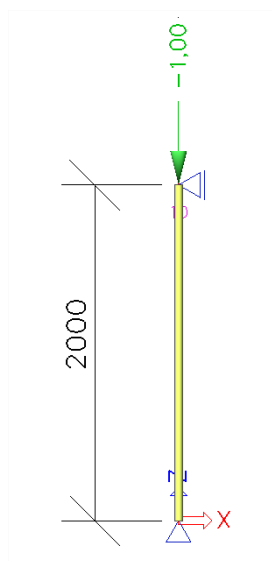

Calculation of the buckling shape



First a **Stability calculation** is done using a load of 1kN. This way, the elastic critical buckling load  $N_{cr}$  is obtained. In order to obtain precise results, the **Number of 1D elements** is set to **10**. In addition, the **Shear Force Deformation** is neglected so the result can be checked by a manual calculation. The stability calculation gives the following result:

### Critical load coefficients

N	f
-	[ ]
Stability combination : S1	
1	60,11

This can be verified with Euler's formula using the member length as the buckling length:

$$N_{cr} = \frac{\pi^2 EI}{l^2} = \frac{\pi^2 \cdot 210.000 \frac{N}{mm^2} \cdot 116000 mm^4}{(2000 mm)^2} = 60105,89 N$$

The following picture shows the mesh nodes of the column and the corresponding buckling shape:

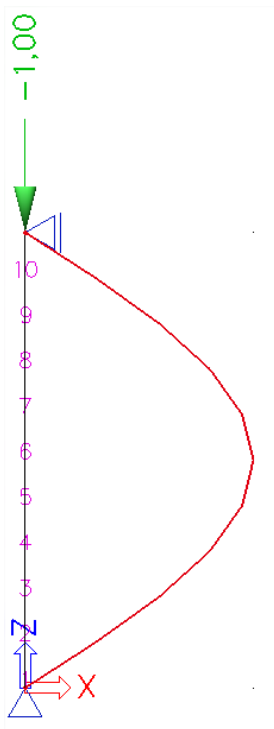

### Displacement of nodes

Stability calculation, Extreme : No

Selection : All

Stability combinations : S1/1 - 60,11

Buckling shapes are dimensionless, units are printed for consistency purposes.

Node of mesh	Case	Ux [mm]	Uz [mm]	Fy [mrad]
1	S1/1 - 60,11	0,0	0,0	1000,0
11	S1/1 - 60,11	196,7	0,0	951,1
3	S1/1 - 60,11	374,2	0,0	809,0
4	S1/1 - 60,11	515,0	0,0	587,8
5	S1/1 - 60,11	605,5	0,0	309,0
6	S1/1 - 60,11	636,6	0,0	0,0
7	S1/1 - 60,11	605,5	0,0	-309,0
8	S1/1 - 60,11	515,0	0,0	-587,8
9	S1/1 - 60,11	374,2	0,0	-809,0
10	S1/1 - 60,11	196,7	0,0	-951,1
2	S1/1 - 60,11	0,0	0,0	-1000,0

Using for example an Excel worksheet, the buckling shape can be approximated by a 4<sup>th</sup> grade polynomial.

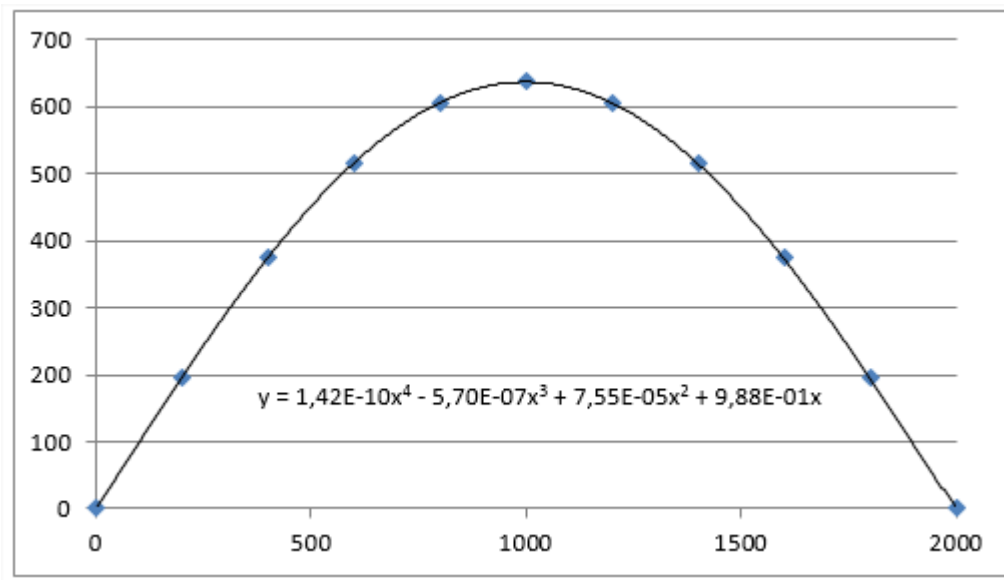

A polynomial has the advantage that the second derivative can easily be calculated.

$$\Rightarrow \eta_{cr} = 1,42E^{-10} x^4 - 5,70E^{-7} x^3 + 7,55E^{-5} x^2 + 9,88E^{-1} x$$

$$\Rightarrow \eta_{cr,max}'' = 1,70E^{-09} x^2 - 3,43E^{-6} x + 1,51E^{-4}$$

#### Calculation of $e_0$

$$N_{Rk} = f_y \times A = 235 \frac{N}{mm^2} \times 453 mm^2 = 106455 \text{ N}$$

$$M_{Rk} = f_y \times W_{pl} = 235 \frac{N}{mm^2} \times 6508,8 mm^3 = 1529568 \text{ Nmm}$$

$$\bar{\lambda} = \sqrt{\frac{N_{Rk}}{N_{cr}}} = \sqrt{\frac{106455 N}{60110 N}} = 1,33$$

$\alpha = 0,21$  for buckling curve a

$$\chi = \frac{1}{0,5[1 + \alpha(\bar{\lambda} - 0,2) + (\bar{\lambda})^2] + \sqrt{(0,5[1 + \alpha(\bar{\lambda} - 0,2) + (\bar{\lambda})^2])^2 - (\bar{\lambda})^2}} = 0,45$$

These intermediate results can be verified through SCIA ENGINEER when performing a Steel Code Check on the column:

Buckling parameters	yy	zz	
Sway type	sway	non-sway	
System length L	2,000	2,000	m
Buckling factor k	1,00	1,00	
Buckling length L <sub>cr</sub>	2,000	2,000	m
Critical Euler load N <sub>cr</sub>	60,11	60,11	kN
Slenderness Lambda	124,98	124,98	
Relative slenderness Lambda,rel	1,33	1,33	
Limit slenderness Lambda,rel,0	0,20	0,20	
Buckling curve	a	a	
Imperfection Alpha	0,21	0,21	
Reduction factor Chi	0,45	0,45	
Buckling resistance N <sub>b,Rd</sub>	48,27	48,27	kN

$$\Rightarrow e_0 = \alpha \cdot (\bar{\lambda} - 0,2) \cdot \frac{M_{Rk}}{N_{Rk}} \cdot \frac{1 - \chi \cdot (\bar{\lambda})^2}{1 - \chi \cdot (\bar{\lambda})^2} = 0,21 \cdot (1,33 - 0,2) \cdot \frac{1529568 Nmm}{106455 N}$$

$$= 3,41 \text{ mm}$$

The required parameters have now been calculated so in the final step the amplitude of the imperfection can be determined.

#### Calculation of $\eta_{init}$

The mid section of the column is decisive  $\Rightarrow x = 1000$

$$\eta_{cr} \text{ at mid section} = 636,6$$

$$\eta_{cr,max}'' \text{ at mid section} = 1,57E^{-03} \text{ 1/mm}^2$$

$$\Rightarrow \eta_{init} = e_0 \cdot \frac{N_{cr}}{E \cdot I_y \cdot \eta_{cr,max}''} \cdot \eta_{cr}$$

$$= 3,41 \text{ mm} \cdot \frac{60110 N}{210000 \text{ N/mm}^2 \cdot 116000 \text{ mm}^4 \cdot 1,57E^{-3} \text{ 1/mm}^2} \cdot 636,6$$

$$= 3,42 \text{ mm}$$

This value can now be inputted as amplitude of the buckling shape for imperfection.

To illustrate this, the column is loaded by a compression load equal to its buckling resistance.

However, due to the imperfection, an additional moment will occur which will influence the section check. The buckling resistance can be calculated as follows:

$$N_{Ed} = N_{b,Rd} = \frac{\chi \cdot A \cdot f_y}{\gamma_{M1}} = 0,45 \cdot 453 \text{ mm}^2 \cdot 235 \text{ N/mm}^2 = 47,90 \text{ kN}$$

A non-linear combination is created in which the buckling shape as imperfection is specified.

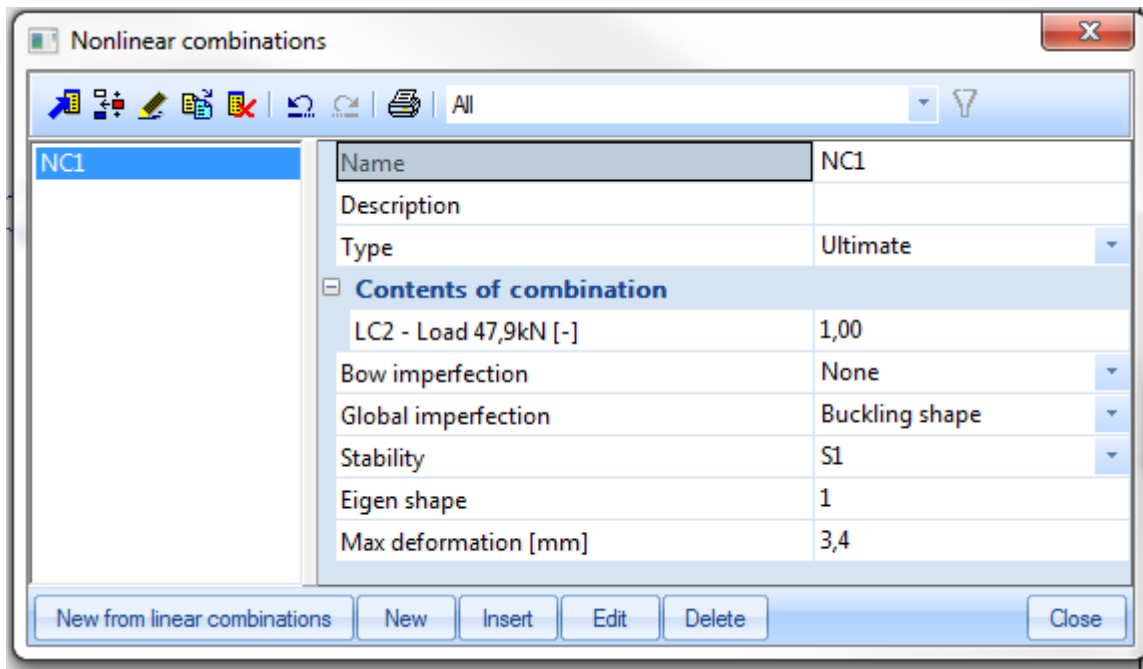

Using this combination, a non-linear **2<sup>nd</sup> Order** calculation is executed using **Timoshenko's method**.

The additional moment can be easily calculated as follows:

$$M_{\eta,init} = N_{Ed} \cdot \eta_{init} \cdot \frac{1}{1 - \frac{N_{Ed}}{N_{cr}}} = 47,90kN \cdot 0,00342m \cdot \frac{1}{1 - \frac{47,90kN}{60,11kN}}$$

$$= \mathbf{0,80 \text{ kNm}}$$

When performing a Steel Code Check on the column for the non-linear combination, this can be verified. The critical check is performed at **1m** and has the following effects:

**...:SECTION CHECK:...:**

**The critical check is on position 1.000 m**

Internal forces	Calculated	Unit
N,Ed	-47,90	kN
Vy,Ed	0,00	kN
Vz,Ed	0,04	kN
T,Ed	0,00	kNm
My,Ed	0,80	kNm
Mz,Ed	0,00	kNm

The additional moment thus corresponds to the moment calculated by SCIA Engineer.

As seen in the diagram, **Path 3** is followed: the buckling shape serves as a unique global and local imperfection. This implies that only a section check and Lateral Torsional Buckling need to be checked. Since LTB is negligible with this small bending moment, only a section check is required:

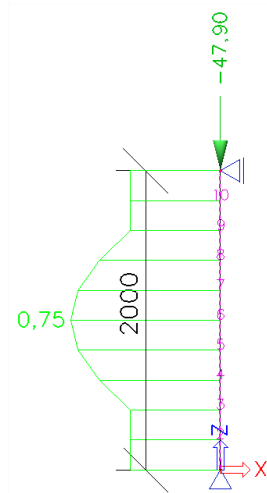

### Scaffolding check for tubular members

According to EN 12811-1:2003, art. 10.3.3.2 and equation 9

Table of values		
Npl.d	106,46	kN
Vpl.d	39,13	kN
Mpl.d	1,41	kNm
Unity check N	0,45	
Unity check V	0,00	
Unity check M	0,57	
Unity check Interaction	0,75	
Unity check Max	0,75	-

The member satisfies the section check.

This example has illustrated the use of a buckling shape as imperfection. Depending on the geometry of the structure, this imperfection can have a large influence on the results due to the additional moments which occur.

When using this method, it is very important to double check all applied steps: small changes to the loading or geometry require a re-calculation of the buckling shape and amplitude before a non-linear analysis may be carried out.

As a final note: the buckling shape only gives information about a specific zone of the structure. The imperfection is applied at that zone and results/checks are only significant for that zone. Other combinations of loads will lead to another buckling shape thus to each load combination a specific buckling shape must be assigned and a steel code check should only be used on those members on which the imperfection applies. Since the applied buckling shape corresponds to a global mode, failure of these members will lead to a collapse of the structure.

## 10. Input Hinge Types and non-linear stiffness

### Couplers

#### General principle

For connections in a scaffolding structure, a check has to be performed on the normal forces, the shear forces and the moments. Various connection types are inserted in SCIA Engineer. For the different connections, go to “Libraries -> Structure, Analysis -> Hinge type”.

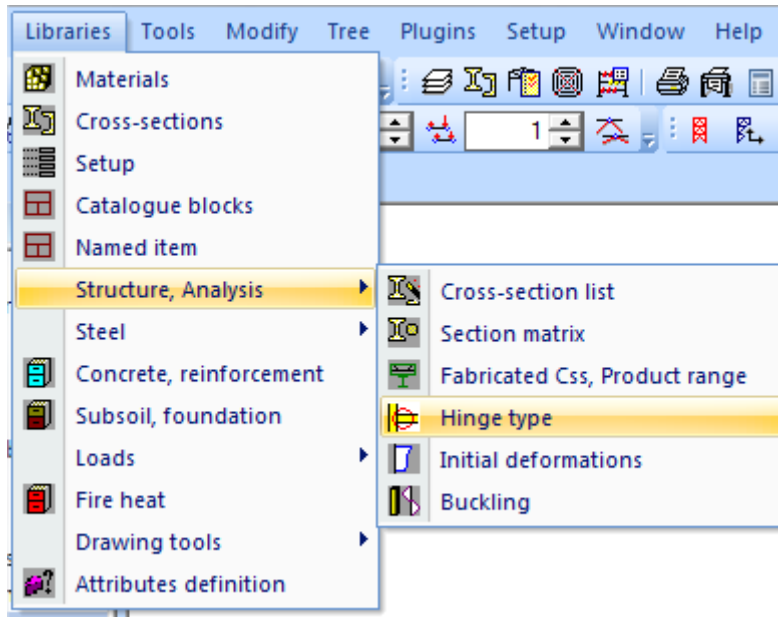

In this “Hinge type library” you can choose following types at the option” Hinge type”:

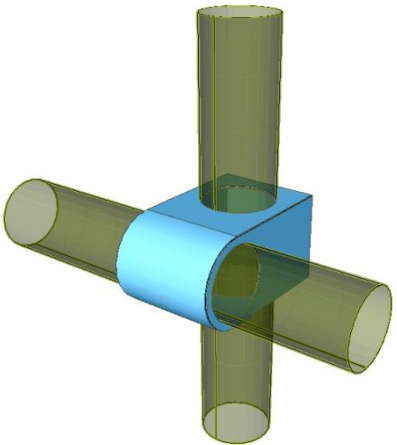
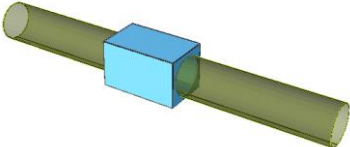
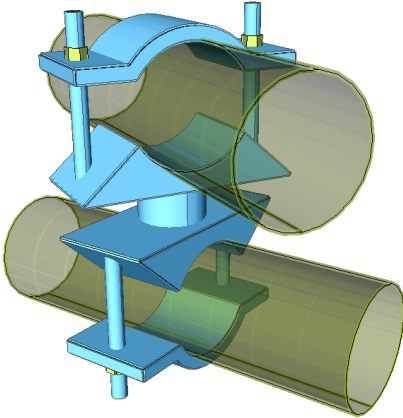
Right angle coupler	Friction sleeve	Swivel coupler
		

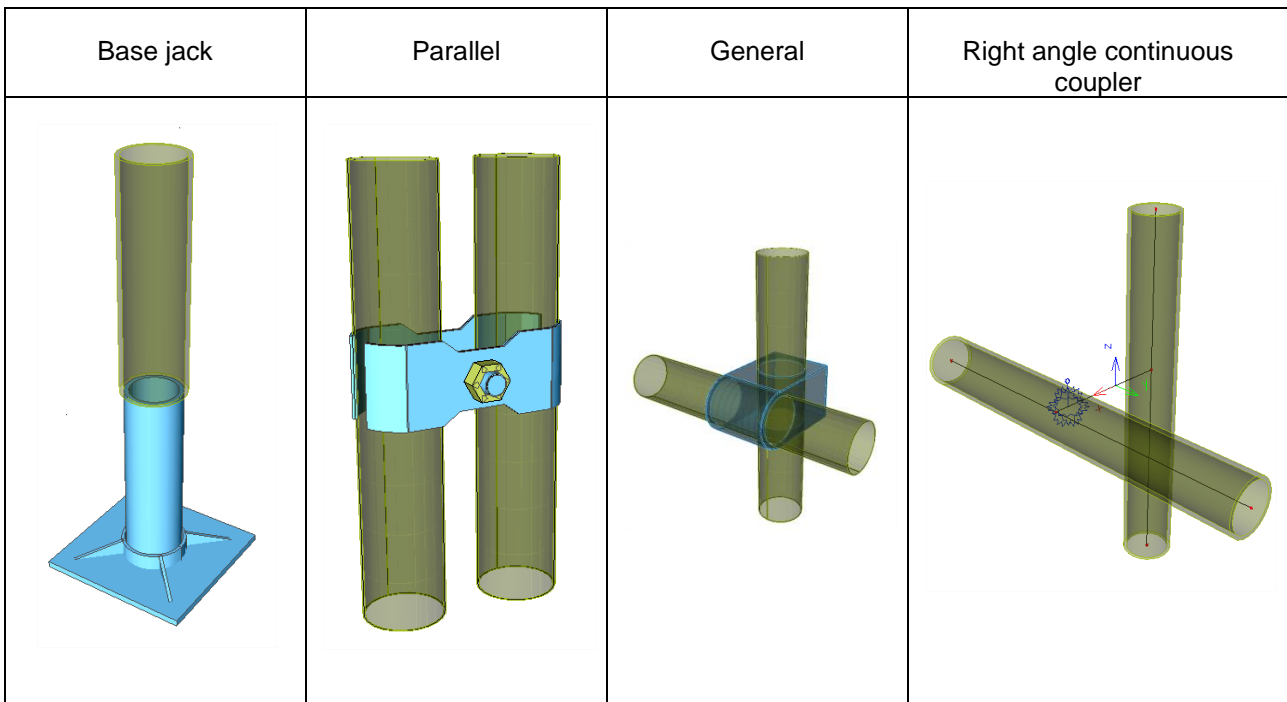

In this connection, not only the rigidities are entered in a flexible or non-linear way, but specifically for these connections, the maximal allowable forces can also be inserted, as displayed below for the Right angled couplers:

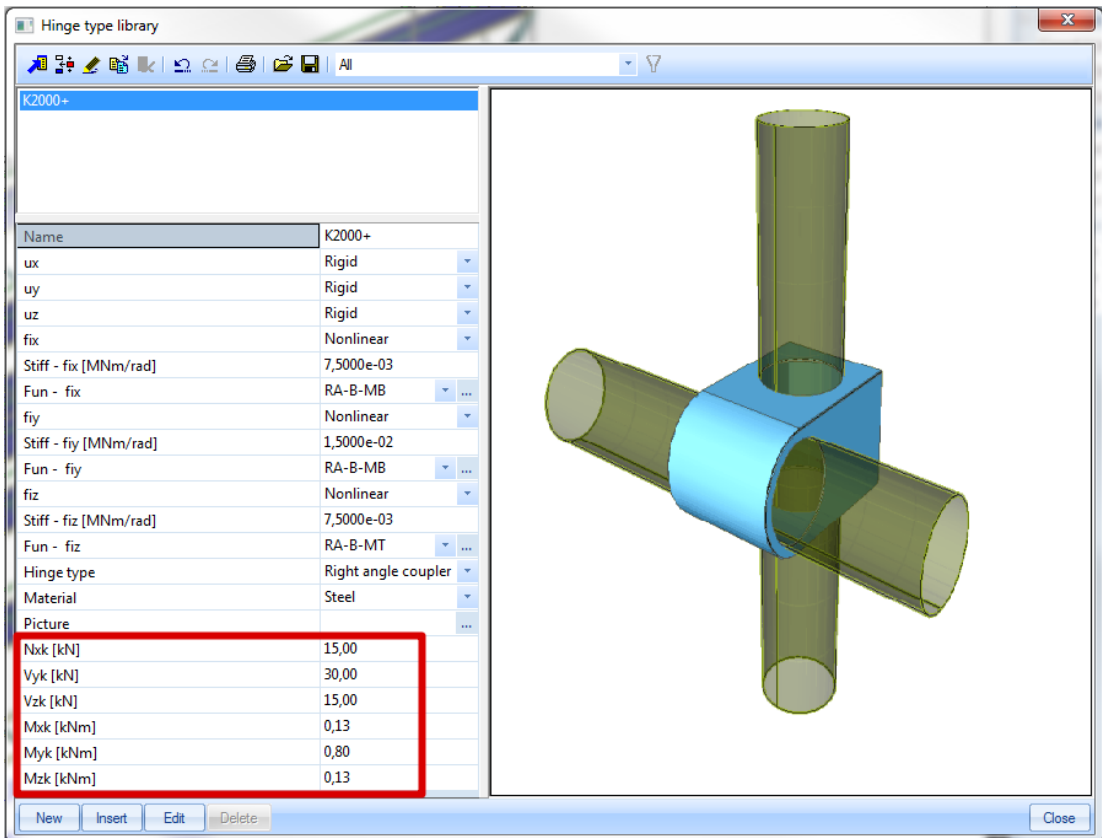

The rigidities are filled out and the maximal forces have to be obtained from the info of the connections, provided by the supplier.

## Manual input

In this example, a connection of Layher is being adopted (K2000+):



For this connection, it is advisable to enter a general connection containing the properties of Zulassung Z-8.22-64. For this purpose, the following maximal forces are displayed:

$$M_{y,R,d} = 111 \text{ kNcm} (=1,11 \text{ kNm})$$

$$M_{z,R,d} = 41 \text{ kNcm} (=0,41 \text{ kNm})$$

$$V_{y,R,d} = 11 \text{ kN}$$

$$V_{z,R,d} = 29,04 \text{ kN}$$

$$N_{D,R,d} = 34,1 \text{ kN}$$

$$\varphi_d [\text{rad}] = M / (9140 - 73,6M)$$

The equation above for the rotation gives the following rotation curve:

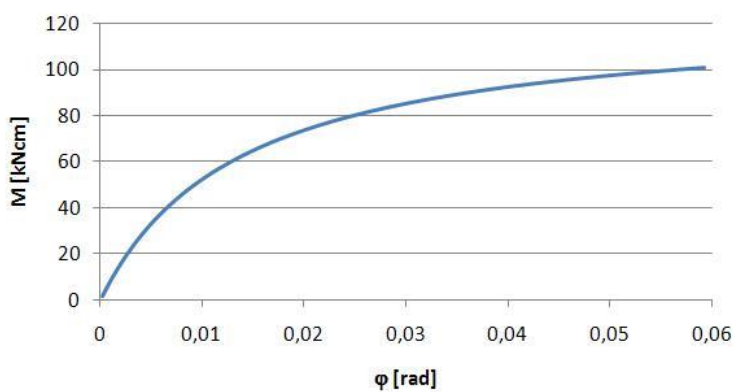



To enter this correctly, it should be performed using a non-linear spring or a non-linear function in SCIA Engineer:

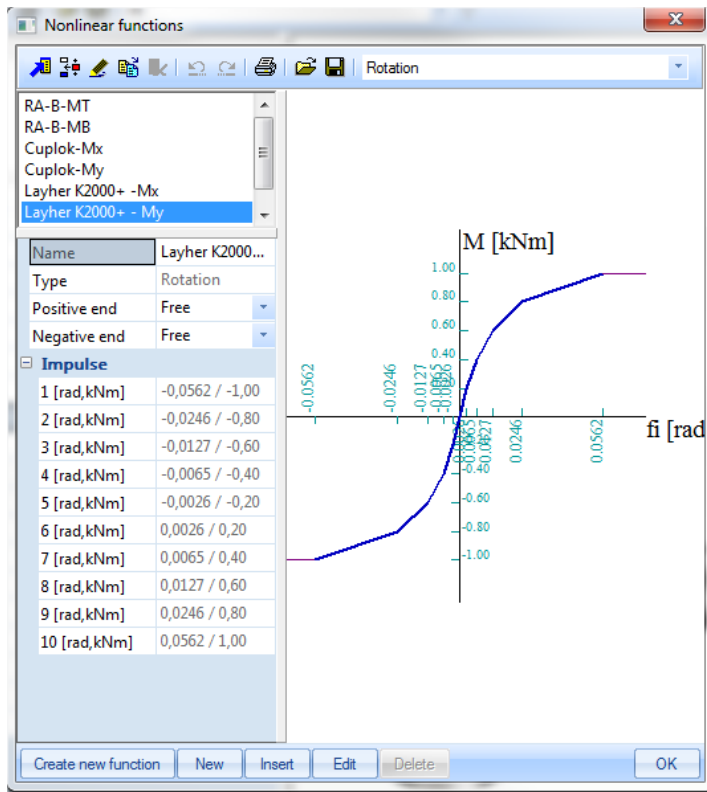

If everything is being filled out in the values for this hinge, the following dialog appears:

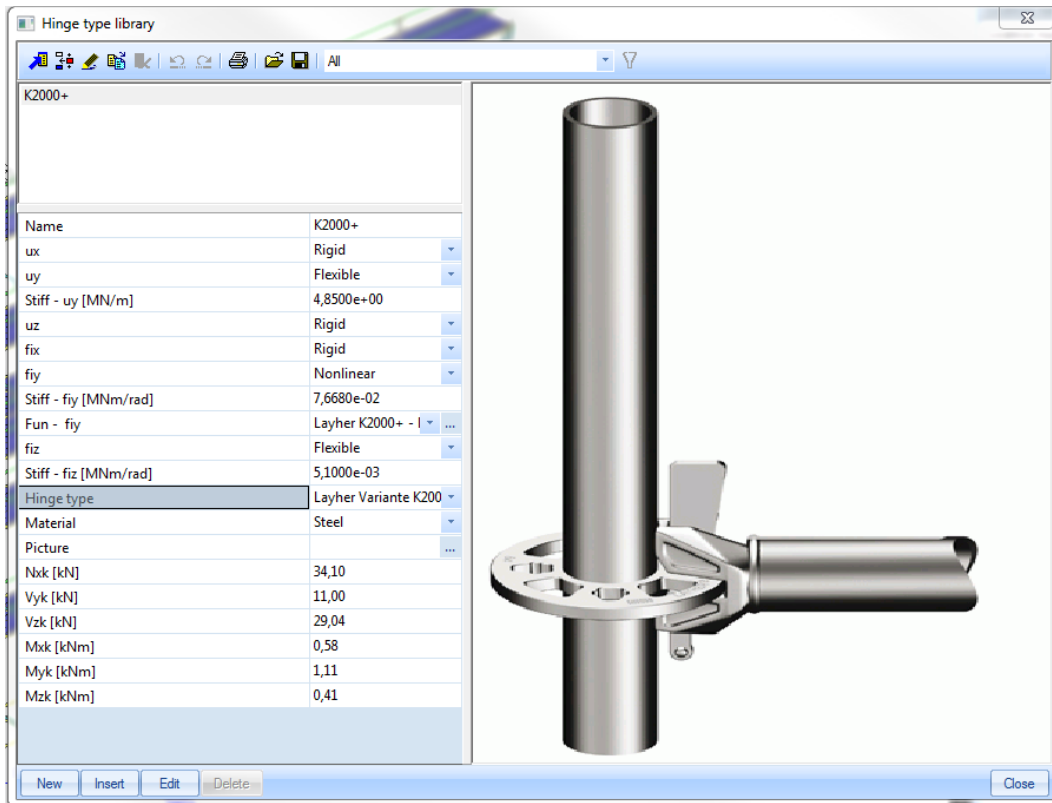

It is assumed that the translations are “rigid” in all directions. Also the rotation around the x-axis is considered as “fixed”. This is only a rough estimate. For the rotation around the y-axis, the non-linear function (determined earlier) is entered with a linear rigidity of 0,051 MNm/rad. The rotation around the local z-axis will be much smaller than around the y-axis namely 0,0051 MNm/rad.



For the values of  $V_{yk}$ , the same value is taken as for  $V_{yz}$ . This value should be determined by the supplier as well.

For the maximal moments the same conclusion can be drawn.

Subsequently these hinges are attributed to both extremities of the ledgers and guardrails.

## Couplers in SCIA Engineer

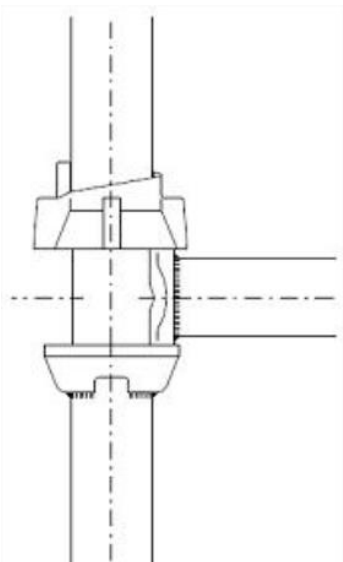
Some couplers are input already in SCIA Engineer:

Cuplock coupler	Layher Variante K2000+	Layher Variante II																																																																																																																																
																																																																																																																																		
<table border="1"> <thead> <tr> <th>Name</th> <th>VarIII</th> </tr> </thead> <tbody> <tr><td>ux</td><td>Nonlinear</td></tr> <tr><td>Stiff - ux [MN/m]</td><td>4,3640e+01</td></tr> <tr><td>Fun - ux</td><td>Cuplok-N</td></tr> <tr><td>uy</td><td>Rigid</td></tr> <tr><td>uz</td><td>Rigid</td></tr> <tr><td>fix</td><td>Nonlinear</td></tr> <tr><td>Stiff - fix [MNm/rad]</td><td>1,8270e-02</td></tr> <tr><td>Fun - fix</td><td>Cuplok-Mx</td></tr> <tr><td>fiy</td><td>Nonlinear</td></tr> <tr><td>Stiff - fiy [MNm/rad]</td><td>6,5000e-02</td></tr> <tr><td>Fun - fiy</td><td>Cuplok-My</td></tr> <tr><td>fiz</td><td>Flexible</td></tr> <tr><td>Stiff - fiz [MNm/rad]</td><td>2,5000e-03</td></tr> <tr><td>Hinge type</td><td>Cuplok coupler</td></tr> <tr><td>Material</td><td>Steel</td></tr> <tr><td>Picture</td><td>...</td></tr> <tr><td>Nxk [kN]</td><td>54,12</td></tr> <tr><td>Vyk [kN]</td><td>0,00</td></tr> <tr><td>Vzk up [kN]</td><td>18,15</td></tr> <tr><td>Vzk down [kN]</td><td>21,78</td></tr> <tr><td>Mxk [kNm]</td><td>1,04</td></tr> </tbody> </table>	Name	VarIII	ux	Nonlinear	Stiff - ux [MN/m]	4,3640e+01	Fun - ux	Cuplok-N	uy	Rigid	uz	Rigid	fix	Nonlinear	Stiff - fix [MNm/rad]	1,8270e-02	Fun - fix	Cuplok-Mx	fiy	Nonlinear	Stiff - fiy [MNm/rad]	6,5000e-02	Fun - fiy	Cuplok-My	fiz	Flexible	Stiff - fiz [MNm/rad]	2,5000e-03	Hinge type	Cuplok coupler	Material	Steel	Picture	...	Nxk [kN]	54,12	Vyk [kN]	0,00	Vzk up [kN]	18,15	Vzk down [kN]	21,78	Mxk [kNm]	1,04	<table border="1"> <thead> <tr> <th>Name</th> <th>VarIII</th> </tr> </thead> <tbody> <tr><td>ux</td><td>Rigid</td></tr> <tr><td>uy</td><td>Flexible</td></tr> <tr><td>Stiff - uy [MN/m]</td><td>4,8500e+00</td></tr> <tr><td>uz</td><td>Rigid</td></tr> <tr><td>fix</td><td>Nonlinear</td></tr> <tr><td>Stiff - fix [MNm/rad]</td><td>1,3876e-03</td></tr> <tr><td>Fun - fix</td><td>Layher K2000+ - Mx</td></tr> <tr><td>fiy</td><td>Nonlinear</td></tr> <tr><td>Stiff - fiy [MNm/rad]</td><td>7,6680e-02</td></tr> <tr><td>Fun - fiy</td><td>Layher K2000+ - My</td></tr> <tr><td>fiz</td><td>Flexible</td></tr> <tr><td>Stiff - fiz [MNm/rad]</td><td>5,1000e-03</td></tr> <tr><td>Hinge type</td><td>Layher Variante K2000+</td></tr> <tr><td>Material</td><td>Steel</td></tr> <tr><td>Picture</td><td>...</td></tr> <tr><td>Nxk [kN]</td><td>34,10</td></tr> <tr><td>Vyk [kN]</td><td>11,00</td></tr> <tr><td>Vzk [kN]</td><td>29,04</td></tr> <tr><td>Mxk [kNm]</td><td>0,58</td></tr> <tr><td>Myk [kNm]</td><td>1,11</td></tr> <tr><td>Mzk [kNm]</td><td>0,41</td></tr> </tbody> </table>	Name	VarIII	ux	Rigid	uy	Flexible	Stiff - uy [MN/m]	4,8500e+00	uz	Rigid	fix	Nonlinear	Stiff - fix [MNm/rad]	1,3876e-03	Fun - fix	Layher K2000+ - Mx	fiy	Nonlinear	Stiff - fiy [MNm/rad]	7,6680e-02	Fun - fiy	Layher K2000+ - My	fiz	Flexible	Stiff - fiz [MNm/rad]	5,1000e-03	Hinge type	Layher Variante K2000+	Material	Steel	Picture	...	Nxk [kN]	34,10	Vyk [kN]	11,00	Vzk [kN]	29,04	Mxk [kNm]	0,58	Myk [kNm]	1,11	Mzk [kNm]	0,41	<table border="1"> <thead> <tr> <th>Name</th> <th>VarIII</th> </tr> </thead> <tbody> <tr><td>ux</td><td>Rigid</td></tr> <tr><td>uy</td><td>Flexible</td></tr> <tr><td>Stiff - uy [MN/m]</td><td>4,8500e+00</td></tr> <tr><td>uz</td><td>Rigid</td></tr> <tr><td>fix</td><td>Rigid</td></tr> <tr><td>fiy</td><td>Nonlinear</td></tr> <tr><td>Stiff - fiy [MNm/rad]</td><td>1,2800e-01</td></tr> <tr><td>Fun - fiy</td><td>Layher II - My</td></tr> <tr><td>fiz</td><td>Flexible</td></tr> <tr><td>Stiff - fiz [MNm/rad]</td><td>5,1000e-03</td></tr> <tr><td>Hinge type</td><td>Layher Variante II</td></tr> <tr><td>Material</td><td>Steel</td></tr> <tr><td>Picture</td><td>...</td></tr> <tr><td>Nxk [kN]</td><td>24,97</td></tr> <tr><td>Vyk [kN]</td><td>7,37</td></tr> <tr><td>Vzk [kN]</td><td>19,14</td></tr> <tr><td>Mxk [kNm]</td><td>0,00</td></tr> <tr><td>Myk [kNm]</td><td>0,75</td></tr> <tr><td>Mzk [kNm]</td><td>0,41</td></tr> </tbody> </table>	Name	VarIII	ux	Rigid	uy	Flexible	Stiff - uy [MN/m]	4,8500e+00	uz	Rigid	fix	Rigid	fiy	Nonlinear	Stiff - fiy [MNm/rad]	1,2800e-01	Fun - fiy	Layher II - My	fiz	Flexible	Stiff - fiz [MNm/rad]	5,1000e-03	Hinge type	Layher Variante II	Material	Steel	Picture	...	Nxk [kN]	24,97	Vyk [kN]	7,37	Vzk [kN]	19,14	Mxk [kNm]	0,00	Myk [kNm]	0,75	Mzk [kNm]	0,41
Name	VarIII																																																																																																																																	
ux	Nonlinear																																																																																																																																	
Stiff - ux [MN/m]	4,3640e+01																																																																																																																																	
Fun - ux	Cuplok-N																																																																																																																																	
uy	Rigid																																																																																																																																	
uz	Rigid																																																																																																																																	
fix	Nonlinear																																																																																																																																	
Stiff - fix [MNm/rad]	1,8270e-02																																																																																																																																	
Fun - fix	Cuplok-Mx																																																																																																																																	
fiy	Nonlinear																																																																																																																																	
Stiff - fiy [MNm/rad]	6,5000e-02																																																																																																																																	
Fun - fiy	Cuplok-My																																																																																																																																	
fiz	Flexible																																																																																																																																	
Stiff - fiz [MNm/rad]	2,5000e-03																																																																																																																																	
Hinge type	Cuplok coupler																																																																																																																																	
Material	Steel																																																																																																																																	
Picture	...																																																																																																																																	
Nxk [kN]	54,12																																																																																																																																	
Vyk [kN]	0,00																																																																																																																																	
Vzk up [kN]	18,15																																																																																																																																	
Vzk down [kN]	21,78																																																																																																																																	
Mxk [kNm]	1,04																																																																																																																																	
Name	VarIII																																																																																																																																	
ux	Rigid																																																																																																																																	
uy	Flexible																																																																																																																																	
Stiff - uy [MN/m]	4,8500e+00																																																																																																																																	
uz	Rigid																																																																																																																																	
fix	Nonlinear																																																																																																																																	
Stiff - fix [MNm/rad]	1,3876e-03																																																																																																																																	
Fun - fix	Layher K2000+ - Mx																																																																																																																																	
fiy	Nonlinear																																																																																																																																	
Stiff - fiy [MNm/rad]	7,6680e-02																																																																																																																																	
Fun - fiy	Layher K2000+ - My																																																																																																																																	
fiz	Flexible																																																																																																																																	
Stiff - fiz [MNm/rad]	5,1000e-03																																																																																																																																	
Hinge type	Layher Variante K2000+																																																																																																																																	
Material	Steel																																																																																																																																	
Picture	...																																																																																																																																	
Nxk [kN]	34,10																																																																																																																																	
Vyk [kN]	11,00																																																																																																																																	
Vzk [kN]	29,04																																																																																																																																	
Mxk [kNm]	0,58																																																																																																																																	
Myk [kNm]	1,11																																																																																																																																	
Mzk [kNm]	0,41																																																																																																																																	
Name	VarIII																																																																																																																																	
ux	Rigid																																																																																																																																	
uy	Flexible																																																																																																																																	
Stiff - uy [MN/m]	4,8500e+00																																																																																																																																	
uz	Rigid																																																																																																																																	
fix	Rigid																																																																																																																																	
fiy	Nonlinear																																																																																																																																	
Stiff - fiy [MNm/rad]	1,2800e-01																																																																																																																																	
Fun - fiy	Layher II - My																																																																																																																																	
fiz	Flexible																																																																																																																																	
Stiff - fiz [MNm/rad]	5,1000e-03																																																																																																																																	
Hinge type	Layher Variante II																																																																																																																																	
Material	Steel																																																																																																																																	
Picture	...																																																																																																																																	
Nxk [kN]	24,97																																																																																																																																	
Vyk [kN]	7,37																																																																																																																																	
Vzk [kN]	19,14																																																																																																																																	
Mxk [kNm]	0,00																																																																																																																																	
Myk [kNm]	0,75																																																																																																																																	
Mzk [kNm]	0,41																																																																																																																																	

### Layher Variante HS

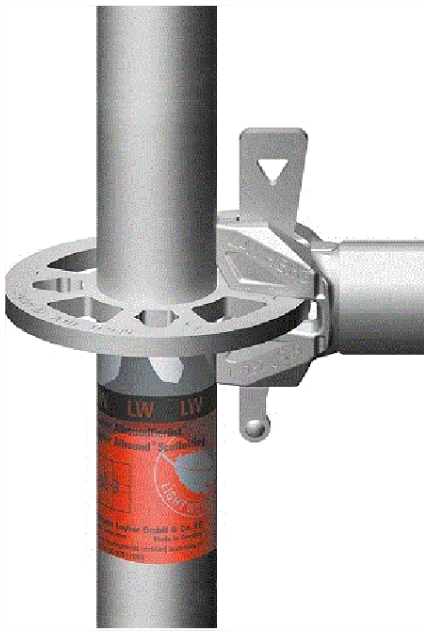

ux	Rigid	▼
uy	Nonlinear	▼
Stiff - uy [MN/m]	8,3330e-01	
Fun - uy	Layher Variante HS - Vy	▼ ...
uz	Rigid	▼
fix	Nonlinear	▼
Stiff - fix [MNm/rad]	2,4620e-03	
Fun - fix	Layher Variante HS - Mx	▼ ...
fiy	Nonlinear	▼
Stiff - fiy [MNm/rad]	1,1560e-01	
Fun - fiy	Layher Variante HS - My	▼ ...
fiz	Nonlinear	▼
Stiff - fiz [MNm/rad]	1,0000e-02	
Fun - fiz	Layher Variante HS - Mz	▼ ...
Hinge type	Layher Variante HS	▼
Material	Steel	▼
Picture		...
Nxk [kN]	38,61	
Vyk [kN]	18,26	
Vzk [kN]	34,87	
Mxk [kNm]	0,58	
Myk [kNm]	1,32	
Mzk [kNm]	0,44	

## Non linear gaps for bracings

For the connection between the wind bracings and the columns, the rotation around the local y-axis is free. There can be a discussion about the rigidity around the z-axis. In this example, it is set on “rigid”, although it cannot be completely considered as “rigid”. If you want to enter the exact value, you have to ask the supplier. The rotation around the x-axis and the translations in the x, y and z direction are “rigid”.

In the direction of the member (local x direction) there is a certain margin of these wind bracings. This can be entered by adopting “Spacings”. For this purpose, all bracings are entered as a “non-linearity” on the members, containing the type “Spacing”.

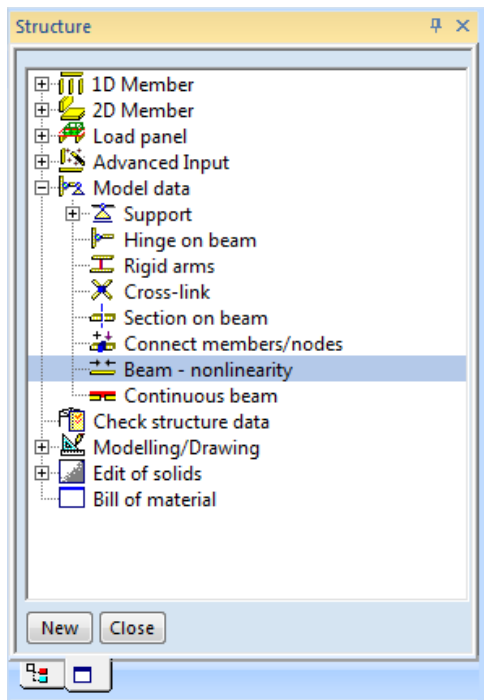

Subsequently a margin of 1 mm per member is entered:

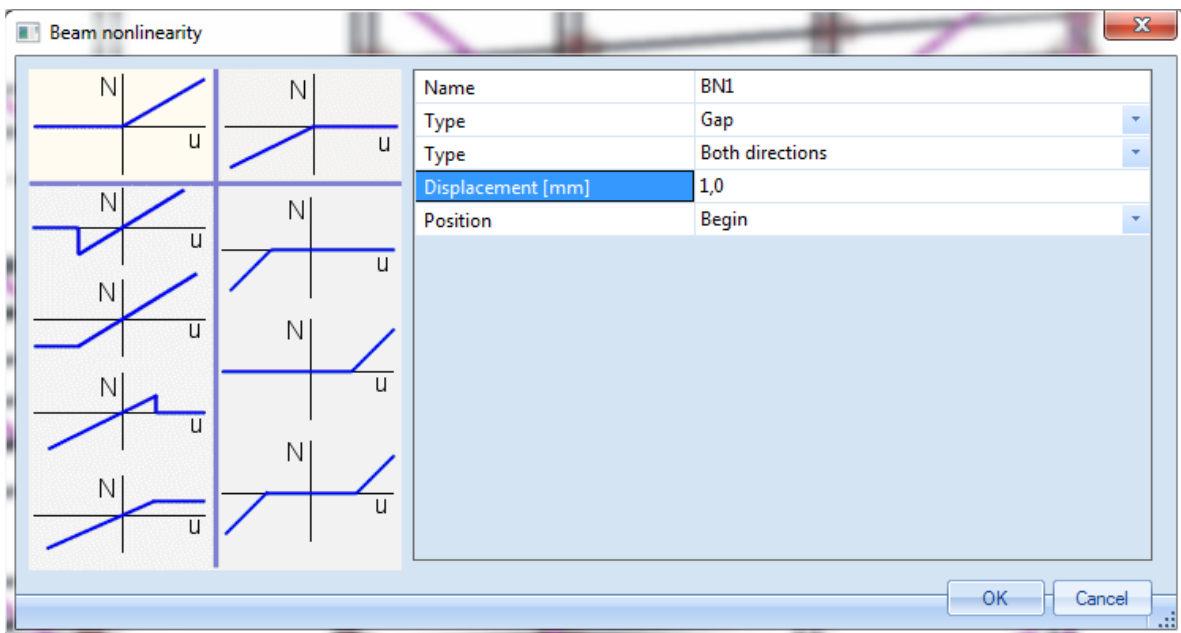

## Non linear supports

It is also better to enter the supports as non-linear supports. In the vertical direction these supports can only take pressure and no tension. This is entered in the z direction with "rigid press only". The rotations are taken free in all directions.

For the degrees of freedom according to the x and y displacements, the code prEN12812:2003, Annex B is applied. In this, the friction coefficients between various materials are entered. If we suppose that the scaffolding is placed on wood, we can see in this code that the maximal and minimal frictions coefficient between wood and steel is 1.2 and 0.5. On average a value of 0.85 is adopted. This value is also entered in SCIA Engineer.

Properties	
Support in node (1)	
Name	Sn11
Type	Standard
Angle [deg]	
Constraint	Custom
X	Friction
From reaction	Z
C flex X [kN/m]	10000,00
mju X	0,85
Y	Friction
From reaction	Z
C flex Y [kN/m]	10000,00
mju Y	0,85
Z	Rigid press only
Independent friction	<input type="checkbox"/>
Rx	Free
Ry	Free
Rz	Free
Default size [m]	0,200
Node	N21
<b>Geometry</b>	
System	GCS

For "C flex" a large value is taken. This corresponds to a large rigidity of the support in the x- and the y-direction before the friction is exceeded.

## 11. Scaffolding Non linear Check

The results of the ULS and SLS check are repeated in this chapter, but now for the non-linear combinations and with the correct stiffness for the connections.

### Relative deformation Check (SLS)

Scaffolding.esa
<ul style="list-style-type: none"> <li>- Choose for "Relative deformation" in the steel menu.</li> <li>- The maximum check is found for beam B349: a unity check of 0,25.</li> </ul> <p>The values of this check are displayed below.</p>

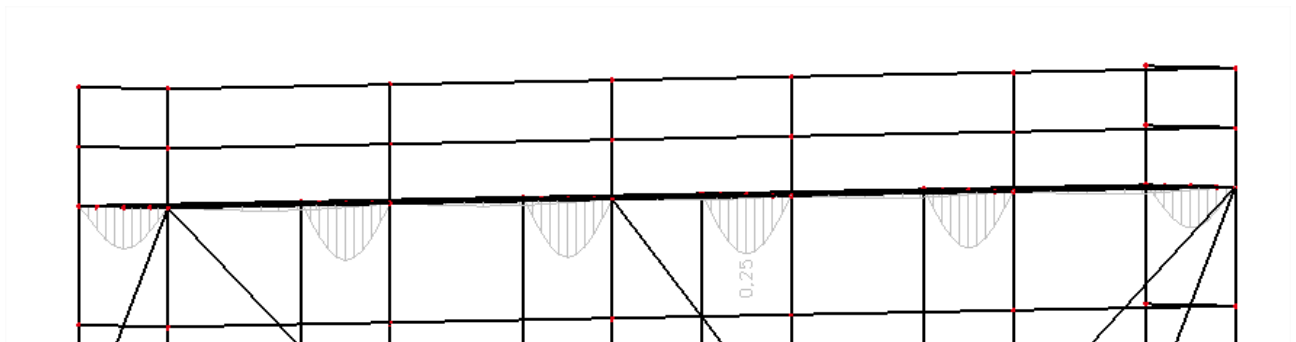

### Relative deformation

Nonlinear calculation, Extreme : Global, System : Principal  
 Selection : All  
 Class : NL SLS  
 Cross-section : Ledger - RO48.3X3.2

Member	dx [m]	Case - combination	uy [mm]	Rel uy [1/xx]	uz [mm]	Rel uz [1/xx]	Check uy [-]	Check uz [-]
B112	1,071	NC7	-0,2	1/10000	-0,2	1/10000	0,01	0,01
B174	1,285	NC7	0,3	1/9968	-0,8	1/3030	0,01	0,03
B349	0,545	NC8	0,0	0	-2,7	1/406	0,00	0,25
B112	0,214	NC8	-0,1	1/10000	0,1	1/10000	0,00	0,00
B54	0,225	NC8	0,0	0	0,1	1/10000	0,00	0,01

## Scaffolding Check (ULS)

Choose for “Scaffolding Check” in the steel code check.

The maximum check is found for beam B347: a unity check of 0,72.

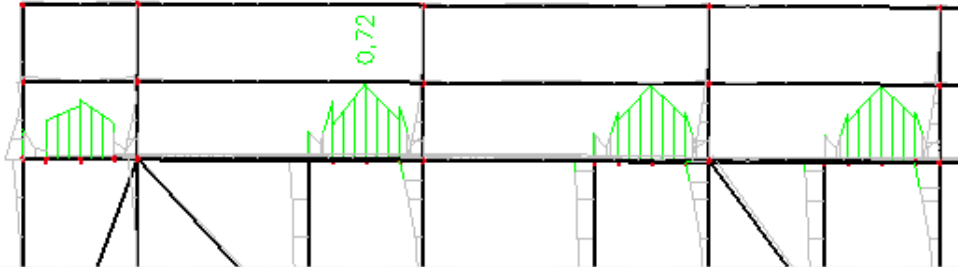

### Check of steel

Nonlinear calculation, Extreme : Global  
Selection : All  
Class : NL ULS

EN 1993-1-1 Code Check  
EN 12811-1 Scaffolding Check  
National annex: Standard EN

Member B347	1,090 m	R048.3X3.2	S 235	NC4	0,72 -
-------------	---------	------------	-------	-----	--------

#### Partial safety factors

Gamma M0 for resistance of cross-sections	1,10
Gamma M1 for resistance to instability	1,10
Gamma M2 for resistance of net sections	1,25

#### Material

Yield strength $f_y$	235,0	MPa
Ultimate strength $f_u$	360,0	MPa
Fabrication	Rolled	

.....SECTION CHECK:....

The critical check is on position 0.545 m

Internal forces	Calculated	Unit
$N_{,Ed}$	-1,30	kN
$V_{y,Ed}$	0,02	kN
$V_{z,Ed}$	-1,57	kN
$T_{,Ed}$	0,00	kNm
$M_{y,Ed}$	0,92	kNm
$M_{z,Ed}$	0,00	kNm

#### Scaffolding check for tubular members

According to EN 12811-1 & DIN 4420 Teil 1 art. 5.4.7.4 and table 7

Table of values		
$N_{pl,d}$	96,78	kN
$V_{pl,d}$	35,57	kN
$M_{pl,d}$	1,28	kNm
Unity check N	0,01	
Unity check V	0,05	
Unity check M	0,72	
Unity check Interaction	0,72	
Unity check Max	0,72	-

The member satisfies the section check.

## 12. Scaffolding – Coupler Check

### Checking the internal forces

When checking the allowable stresses, it is recommended to view the results per profile type (standards, bracings, ...). The maximal stresses can now be compared to the allowable values of the supplier. Also the base jacks are checked with this value.

For the anchorage forces, the reaction force can be tested to the allowable force of a perpendicular coupler. On the other hand, the anchorage can also be checked manually on the combined effect of tension and shear.

For connections this check can be performed by SCIA Engineer itself, with the options "Steel -> Scaffolding - Coupler check".

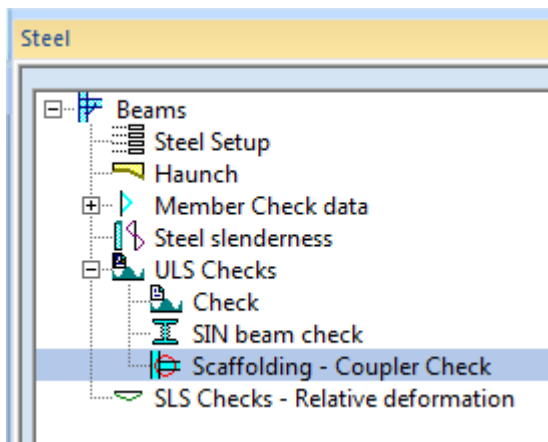

This check performs a unity check for the couplers for which a maximal allowable force is given in the coupler library:

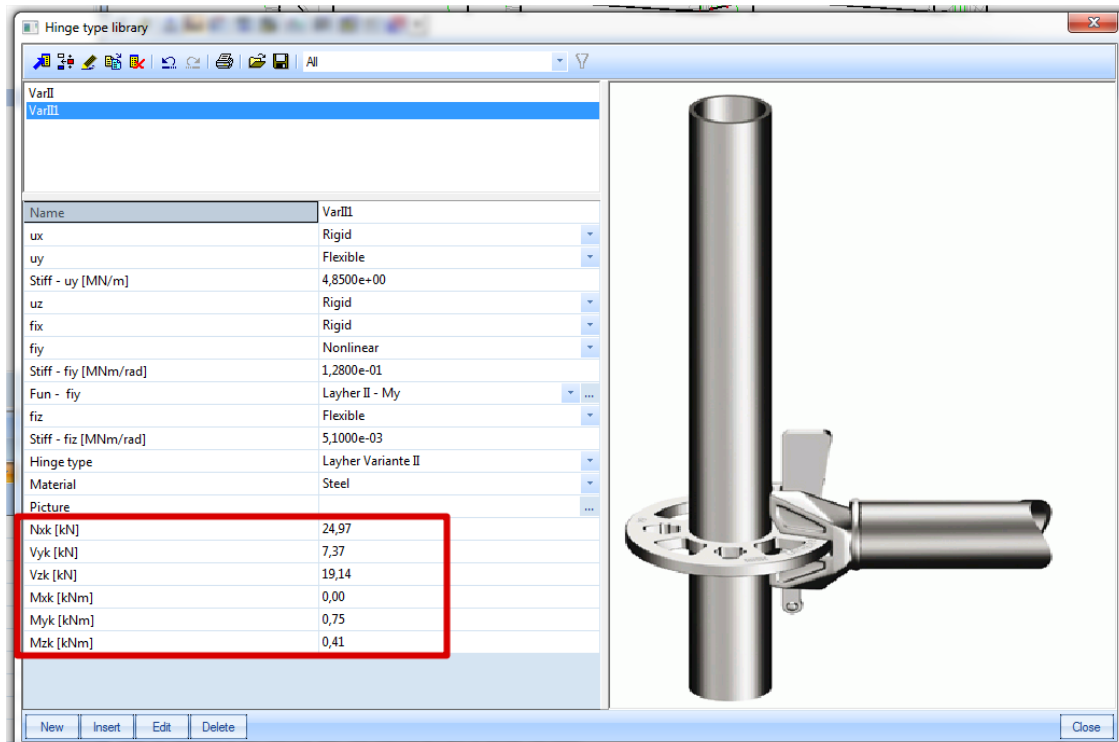



## Interaction check

### General couplers

Next to the check on the internal forces, also an interaction check will be executed. For a general coupler, the following check will be shown:

**Right angle coupler:**

$$\frac{N+V_z}{2 \cdot \frac{F_{sk}}{\gamma_M}} + \frac{V_y}{\frac{F_{pk}}{\gamma_M}} + \frac{M_y}{2,4 \cdot \left(\frac{MBk}{\gamma_M}\right)} \leq 1$$

**Friction sleeve:**

$$\frac{N}{2 \cdot \frac{F_{sk}}{\gamma_M}} + \frac{M_y}{\frac{MBk}{\gamma_M}} \leq 1$$

With

Fsk	Characteristic Slipping force Taken as Nxk and Vz k of the coupler properties $2 \text{ Fsk} = \text{Nxk} + \text{Vzk}$
Fpk	Characteristic Pull-apart force Taken as Vy k of the coupler properties
MBk	Characteristic Bending moment Taken as My k of the coupler properties
N	Normal force
Vy	Shear force in y direction
Vz	Shear force in z direction
My	Bending moment about the y axis
$\gamma_M$	Safety factor taken as $\gamma_{M0}$ of EN 1993-1-1 for steel couplers Safety factor taken as $\gamma_{M1}$ of EN 1999-1-1 for aluminium couplers

### Manufacturer couplers

In addition to the scaffolding couplers listed above, specific manufacturer couplers are provided within SCIA Engineer.

The interaction checks of these couplers are executed according to the respective validation reports.

## Cuplock

The cuplock coupler which connects a ledger and a standard is described in **Zulassung Nr. Z-8.22-208**

The interaction equations are summarised as follows:

$$\text{Interaction 1: } \frac{N}{\frac{M_{xk}}{\gamma_M}} + \frac{M_y}{\frac{M_{yk}}{\gamma_M}} + \frac{M_x}{\frac{M_{xk}}{\gamma_M}} \leq 1$$

$$\text{Interaction 2: } \frac{M_y}{\frac{M_{yk}}{\gamma_M}} + \frac{(N + N_v \cdot \sin(\alpha))}{\frac{N_{xk}}{\gamma_M}} + \frac{M_x}{\frac{M_{xk}}{\gamma_M}} \leq 1$$

With

$N_{xk}$	Taken from the coupler properties
$M_{yk}$	Taken from the coupler properties
$M_{xk}$	Taken from the coupler properties
$N$	Normal force in the ledger
$M_y$	Bending moment around the y-axis
$M_x$	Bending moment around the x-axis
$N_v$	Normal force in a connecting vertical diagonal
$\alpha$	Angle between connecting vertical diagonal and standard
$\gamma_M$	Safety factor taken as $\gamma_{M0}$ of EN 1993-1-1 for steel couplers Safety factor taken as $\gamma_{M1}$ of EN 1999-1-1 for aluminium couplers

## Layher Variante II and K2000+

The cuplock coupler which connects a ledger and a standard is described in **Zulassung Nr. Z-8.22-64**. Both Variante II and K2000+ are provided.

$$\text{Interaction 1: Variante II: } \frac{N^{(+)}}{N_{Rd}} + \frac{M_y}{M_{y,R,d}} + \frac{\max(V_z - 1,4 ; 0)}{M_y} + \frac{V_y}{25,0} \leq 1$$

$$\text{K2000+: } \frac{N^{(+)}}{N_{Rd}} + \frac{M_y}{M_{y,R,d}} + \frac{\max(V_z - 2,1 ; 0)}{M_y} + \frac{V_y}{27,1} + \frac{M_T}{M_{T,R,d}} \leq 1$$

Variante HS: 
$$\frac{N^{(+)}}{N_{Rd}} + \frac{|M_y|}{M_{y,R,d}} + \frac{\max(|V_z|-2,5 ; 0)}{V_{z,R,d}} + \frac{|M_z|}{|M_{z,R,d}|} + \frac{|V_y|}{|V_{y,R,d}|} + \frac{M_T}{M_{T,R,d}} \leq 1$$

Note: An additional check for welds is not supported

Interaction 2: 
$$(n^A + n^B)^2 + (v^A + v^B)^2 \leq 1$$

Ledger A / Vertical diagonal B	
$n^A$	$\frac{N^{A(+)} +  M_y^A  / e}{\xi N_{R,d}}$
$n^B$	$\frac{0,707 \sin \alpha N_V^{(+)} + \left(\frac{e_D}{e}\right) \cdot \cos \alpha  N_V }{\xi N_{R,d}}$
$v^A$	$\frac{V_z^A}{V_{z,R,d}}$
$v^B$	$\frac{\cos \alpha N_V}{V_{z,R,d}}$

With

$N_{R,d}$  =  $N_{xk} / \gamma_M$  with  $N_{xk}$  taken from the coupler properties

$M_{yR,d}$  =  $M_{yk} / \gamma_M$  with  $M_{yk}$  taken from the coupler properties

$M_{zR,d}$  =  $M_{zk} / \gamma_M$  with  $M_{zk}$  taken from the coupler properties

$M_{TR,d}$  =  $M_{xk} / \gamma_M$  with  $M_{xk}$  taken from the coupler properties

$V_{y,R,d}$  =  $V_{yk} / \gamma_M$  with  $V_{yk}$  taken from the coupler properties

$V_{z,R,d}$  =  $V_{zk} / \gamma_M$  with  $V_{zk}$  taken from the coupler properties

$N$  Normal force in the ledger

(+) indicates a tensile force

$V_y$  Shear force in y direction

$V_z$  Shear force in z direction

$M_y$  Bending moment around the y-axis

$M_x$  Bending moment around the x-axis

$N_V$  Normal force in a connecting vertical diagonal

$\alpha$  Angle between connecting vertical diagonal and standard

- e = 2,75 cm for Variante II
- = 3,30 cm for Variante K2000+
- = 3,30 cm for Variante HS
- eD = 5,7 cm for Variante II, Variante K2000+ and Variante HS
- ξ = 1,26 cm for Variante II
- = 1,41 cm for Variante K2000+
- = 1,15 cm for Variante HS
- γ<sub>M</sub> Safety factor taken as γ<sub>M0</sub> of EN 1993-1-1 for steel couplers
- Safety factor taken as γ<sub>M1</sub> of EN 1999-1-1 for aluminium couplers

**Scaffolding.esa**

- Choose for “Scaffolding – Coupler Check” in the steel menu
- Take a look at the check for beam B347: a unity check of 0,47.

The values of this check are displayed below.

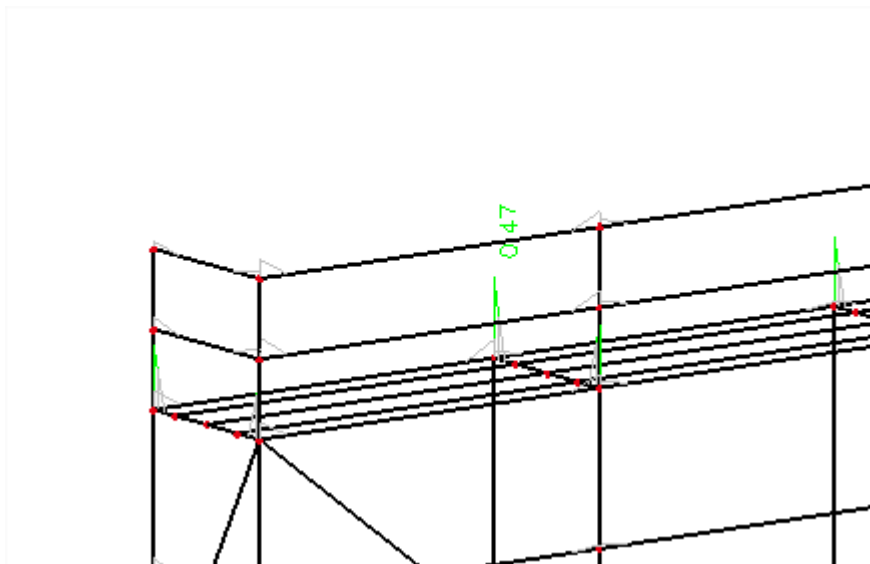

### Scaffolding - coupler check

Nonlinear calculation, Extreme : Global  
 Selection : B347  
 Class : NL ULS  
 Verification of coupler

Name	Member position	Case	Unity Check - Max [-]	Unity Check - Fx [-] Unity Check - Fy [-] Unity Check - Fz [-]	Unity Check - Mx [-] Unity Check - My [-] Unity Check - Mz [-]	Unity Check - Interaction [-] Unity Check - Interaction 2 [-]
K2000+	B347-Both(end)	NL ULS	0,47	0,02 0,02 0,17	0,01 0,34 0,00	0,47 0,09

The coupler reaches a value of 0,47 for the interaction check 1, so this means for the following check (since we were using K2000+ coupler):

$$\frac{N^{(+)}}{N_{Rd}} + \frac{M_y}{M_{y,Rd}} + \frac{\max(V_z - 2,1 ; 0)}{M_y} + \frac{V_y}{27,1} + \frac{M_T}{M_{T,Rd}} \leq 1$$

## 13. Aluminium

The scaffolding checks of aluminium works exactly the same as for the material steel. Also here the checks for Circular Hollow Sections are input in SCIA Engineer and also the coupler check has been input in SCIA Engineer for aluminium couplers.

Because everything is also possible in aluminium in SCIA Engineer, you have to indicate in the couplers of SCIA Engineer, if they are made out of steel or out of aluminium, because this will change the safety factor of the coupler: when choosing for the material aluminium, the safety factor will be taken out of the National Annex of EN 1999-1-1 instead of the EN 1993-1-1:

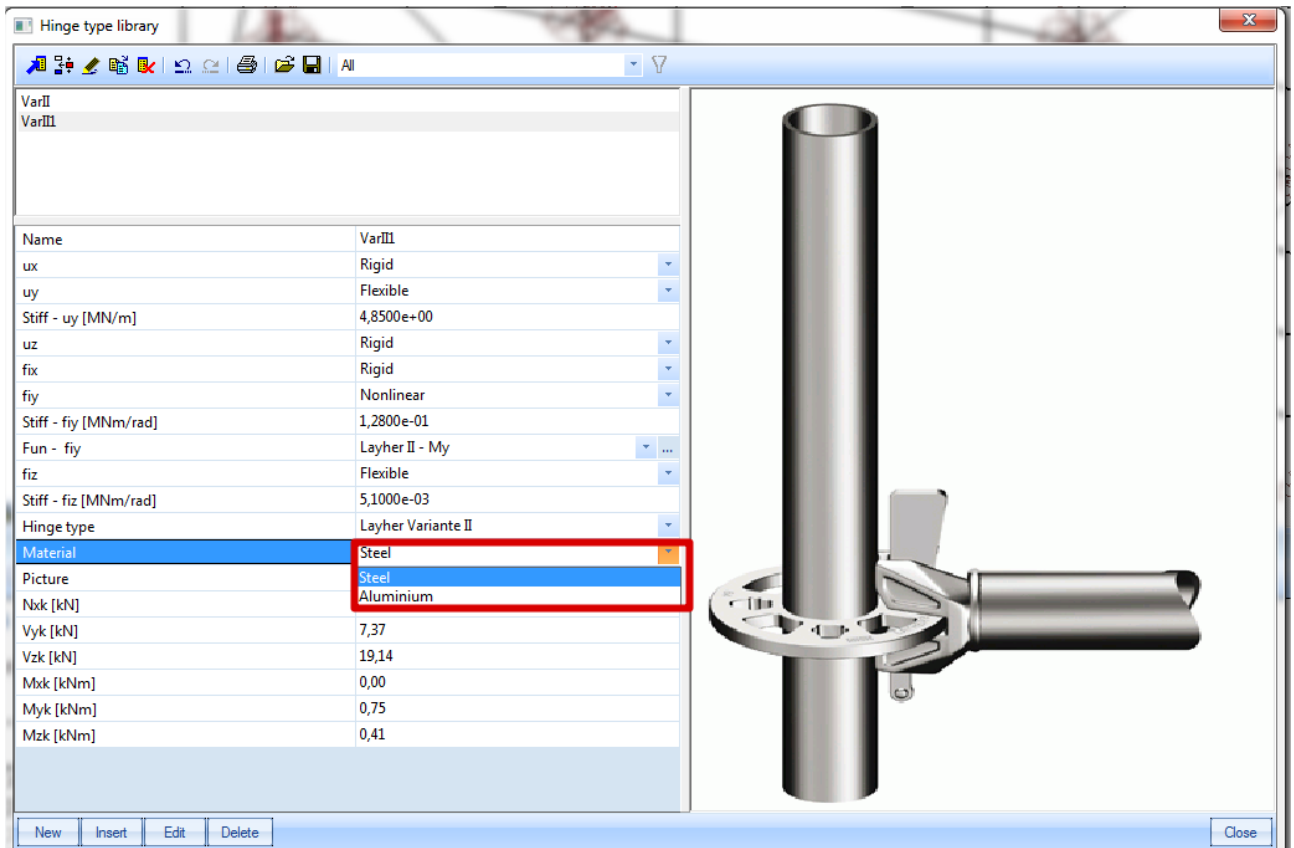

# 14. Engineering Report

The scaffolding checks can be add to the Engineering Report:

The screenshot shows a software interface with a tree view on the left and a report on the right. The tree view includes categories like 'Check of steel', 'Relative deformation', and 'Scaffolding - coupler check'. The report on the right contains the following sections:

### 1. Check of steel

Name	Header
EC 3	Nonlinear calculation, Extreme : Global, Selection : All, Class : NL ULS

MemberB347	1,090 m	RO48.3X3.2	S 235	NC4	0,72 -
------------	---------	------------	-------	-----	--------

#### Partial safety factors

Gamma M0 for resistance of cross-sections	1,10
Gamma M1 for resistance to instability	1,10
Gamma M2 for resistance of net sections	1,25

#### Material

Yield strength fy	235,0	MPa
Ultimate strength fu	360,0	MPa
Fabrication	Rolled	

...SECTION CHECK:...

The critical check is on position 0.545 m

Internal forces	Calculated	Unit
N <sub>Ed</sub>	-1,30	kN
V <sub>y,Ed</sub>	0,02	kN
V <sub>z,Ed</sub>	-1,57	kN
T <sub>Ed</sub>	0,00	kNm
M <sub>y,Ed</sub>	0,92	kNm
M <sub>z,Ed</sub>	0,00	kNm

#### Scaffolding check for tubular members

According to EN 12811-1 & DIN 4420 Teil 1 art. 5.4.7.4and table 7

Table of values		
Npl.d	96,78	kN
Vpl.d	35,57	kN
Mpl.d	1,28	kNm
Unity check N	0,01	
Unity check V	0,05	
Unity check M	0,72	
Unity check Interaction	0,72	
Unity check Max	0,72	-

The member satisfies the section check.

### 2. Relative deformation

Nonlinear calculation, Extreme : Global, System : Principal  
Selection : All  
Class : NL SLS  
Cross-section : Ledger - RO48.3X3.2

Member	dx [m]	Case - combination	uy [mm]	Rel uy [1/xx]	uz [mm]	Rel uz [1/xx]
B112	1,071	NC7	-0,2	1/10000	-0,2	1/10000
B174	1,285	NC7	0,3	1/9967	-0,8	1/3030
B349	0,545	NC8	0,0	0	-2,7	1/406
B112	0,214	NC8	-0,1	1/10000	0,1	1/10000
B54	0,225	NC8	0,0	0	0,1	1/10000

### 3. Scaffolding - coupler check

Nonlinear calculation, Extreme : Global

## 15. Template

To create a template, the following procedure has to be followed:

1. Create a new project or open an existing one.
2. Define all the properties and even parts of a structure that should be included in the template. If an already existing project is used, make any changes that are necessary.
3. When you are satisfied with the result and you think that the current state of the project is what should become the template, save it **As Template** using menu function **File > Save As**.
4. Browse for the folder where the user templates are stored - this folder is specified in the **Setup > Options** dialogue.
5. Type the name of the template file.
6. Complete the action.

With this possibility, it is possible to predefine the cross sections, the (non-linear) combinations, the non linear hinges, the document, ...

After saving a project as a template, this template can be opened just by making a New Project.

## 16. User Blocks

The application of user blocks can be divided into three independent steps. The steps must be carried out in the given order and all of them must be made.

### 1. Creating the user block

A **user block** can be created as a standard project. There are no explicit restrictions to it. Usually, the user will be working on his/her project and either at the end or some time during the design phase s/he decides to make a **user block** of the current state of the project.

Then the only thing that must be done is save the project to the disk. It may be useful, however not compulsory, to use function **Save As** and give the project such a name that gives a hint about the structure in the project.

### 2. Storing the user block to the library

In order to be usable as a **user block**, the project must be stored in the **User block library** folder (see Program settings > Directory settings). This may be achieved in two ways.

- The user specifies the proper path in the **Save As** dialogue (see paragraph above) and saves the project directly to the **User block library** folder.
- The user saves the project to his/her common project folder and then copies the file to the **User block library** folder. The file may be copied in any file-management tool (e.g. Windows Explorer, Total Commander, My Computer dialogue, etc.)

**Tip:** The user blocks may be stored not only in the given **User block library** folder, but they may be arranged in a tree of subfolders. The subfolders may then group user blocks that have something in common. This arrangement may lead to easier and clearer application of user blocks, especially if a long time passes from the time they were created and stored.

When using this tip, all the subfolders can be chosen:

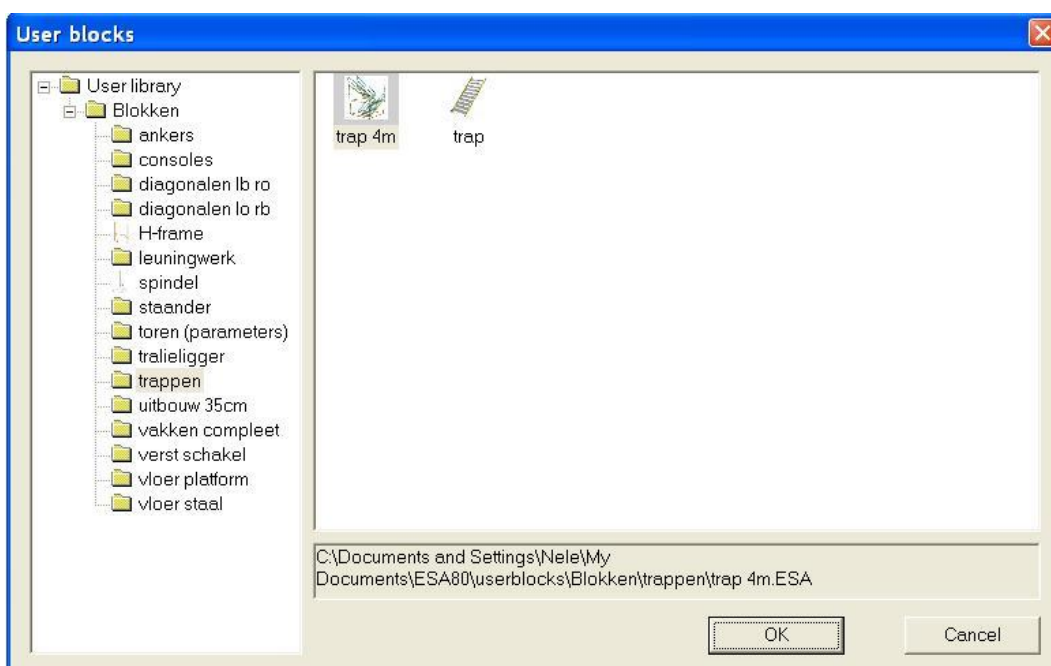



3. Inserting the user block into another project using the following procedure
  1. Open service **Structure**:
    - a. either by means of tree menu function **Structure**,
    - b. or by means of menu function **Tree > Structure**,
    - c. or by means of icon **Structure** on toolbar **Project**.
  2. Select and activate function **User blocks**.
  3. A **User block wizard** opens on the screen. Its left hand side window shows the organisation of the **User block library** folder, i.e. it shows any possible subfolders. The right hand side window then displays all available **user blocks** saved in the appropriate folder or subfolder.
  4. Select the required folder.
  5. Select the required **User block**.
  6. Click **[OK]** in order to insert the block to the current project.
  7. Select the required options for the import (see below).
  8. Position the user block to the desired place and click the left mouse button to put the block there.
  9. If required, repeat the previous step as many times as required or necessary.

**Note:** *If the User block is a parameterised project, the program asks the user to provide all necessary parameters in order to complete the definition of the user block.*

## 17. Attributes

It is possible to add attributes in SCIA Engineer and then make a “bill of material of attributes”. That way you will have a perfect overview of the material needed for the calculated scaffold.

You can make attributes under “Tools -> Attributes definition”:

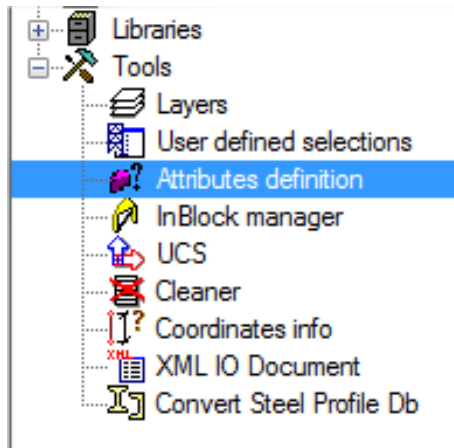

First you have to give your first attribute a name, for example “Ledger”. The most easy way for scaffolds is using “Combobox”:

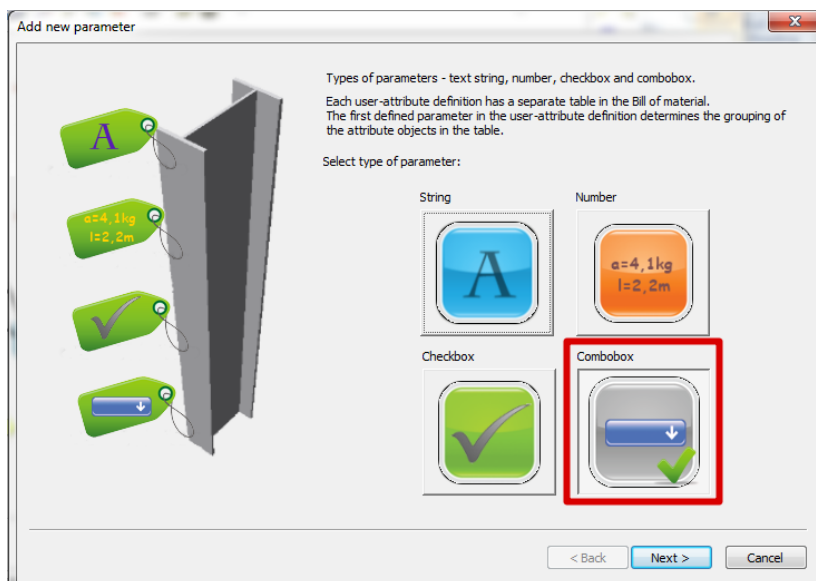

And now you can give the Name and description to the parameter and afterwards all possible “values” like the length of the ledgers in this case. And the most common value could be inputted as the Default value:

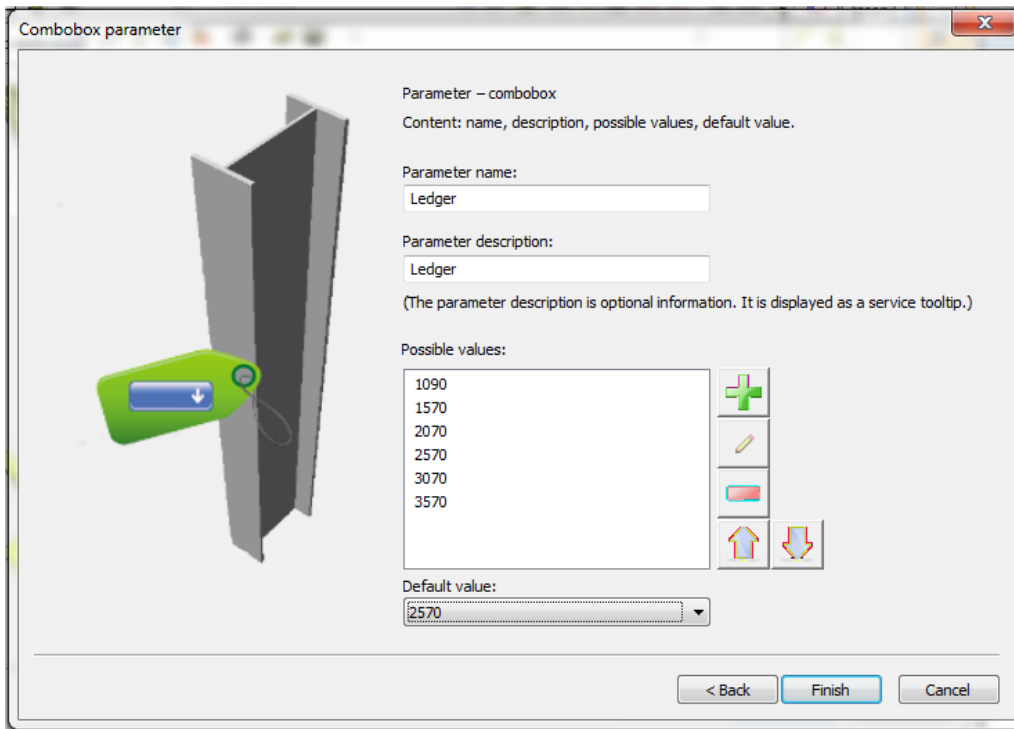

This can be repeated for all the cross-section types and then the label setup can be dedefined:

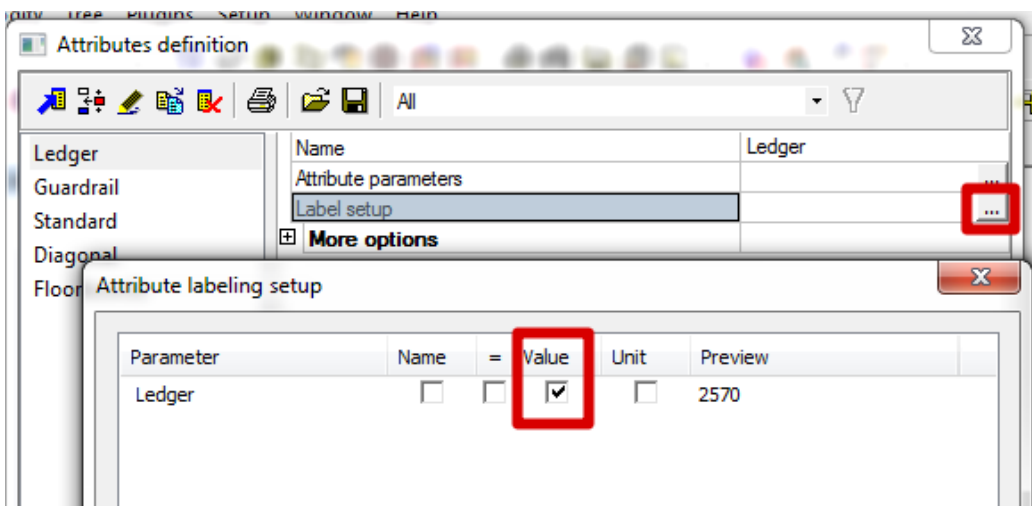

Now with the "Attributes" menu the attributes can be inputted on all members, with as value the correct length.

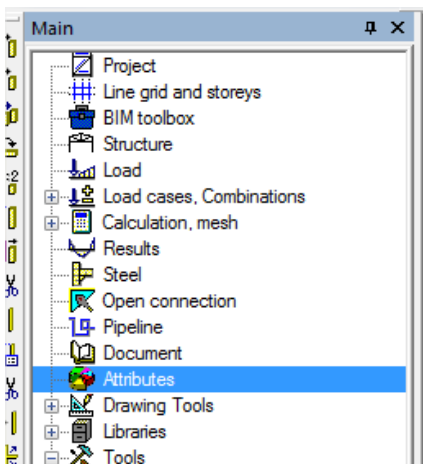

After inputting the attributes, you can always choose to make them invisible on the screen by the “Set view parameters for all” via the tab “Attributes”.

And now you can have a list of all attributes in the document via “New -> Special -> Bill of material by attributes”:

### 1. Bill of material

Type Name	Name	Ledger	Count
Bill Ledger	Ledger	1070	42
Bill Ledger	Ledger	2570	52
Bill Ledger	Ledger	2070	13
Bill Ledger	Total		107

Type Name	Name	Guardrail	Count
Bill Guardrail	Guardrail	1070	66
Bill Guardrail	Guardrail	2570	40
Bill Guardrail	Guardrail	2070	10
Bill Guardrail	Total		116

Type Name	Name	Standard	Count
Bill Standard	Standard	2000	82
Bill Standard	Total		82

Type Name	Name	Diagonal	Count
Bill Diagonal	Diagonal	1,0 - 2,0	16
Bill Diagonal	Diagonal	2,0 - 2,5	10
Bill Diagonal	Diagonal	2,0 - 2,0	5
Bill Diagonal	Total		31

Type Name	Name	Floorboards	Count
Bill Floorboards	Floorboards	2570	72
Bill Floorboards	Floorboards	2070	18
Bill Floorboards	Total		90

## 18. References

- [1] DIN 4420  
Arbeits- und Schutzgerüste  
1990
- [2] HD 1000  
Gevelsteigers bestaande uit prefab onderdelen  
1992
- [3] EN 12811-1  
Scaffolds: Performance requirements and general design  
2003
- [4] EN 12811-3: Scaffolds: Load Testing, 2003
- [5] EN 12810-1  
Façade Scaffolds with Prefabricated Components:  
Products specifications  
2003
- [6] EN 12810-2  
Façade Scaffolds with Prefabricated Components:  
Particular methods of structural design  
2003
- [7] NBN ENV 1991-2-4  
Belasting op draagsystemen: Windbelasting  
1995
- [8] Eurocode 3:  
Design of Steel Structures  
2002  
EN 1993-1-1
- [9] Handbuch des Gerüstbaus  
Friedrich Nather, Hoachim Lindner, Robert Hertle  
2005
- [10] Eurocode 9  
Design of aluminium structures  
Part 1 - 1 : General structural rules  
EN 1999-1-1:2007
- [11] Zulassung Z-8.22-64
- [12] Modeling – Geometric Stiffness – P -  $\Delta$

## 19. Annex A: Wind pressure versus Wind force

In paragraph “6. Load cases” the wind has been calculated with EN1991-1-4 and calculated as a wind pressure.

Following EN 12810-1, it is also possible to calculate the wind as a wind force using the following formula (EN 12810-1, (1)):

$$F_K = c_s \cdot \sum_{i=1}^{i=n} A_i \cdot c_f \cdot q_i$$

With

$A_i$  is the reference area specified in EN 12810-1, Table 4 (see also below)

$c_f$  is the aerodynamic force coefficient taken from EN 12810-1, Table 5 (see also below)

$c_s$  is the site coefficient taken from EN 12810-1, Table 6 (see also below)

$q_i$  is the design velocity pressure in accordance with EN 12810-1, Figure 3:

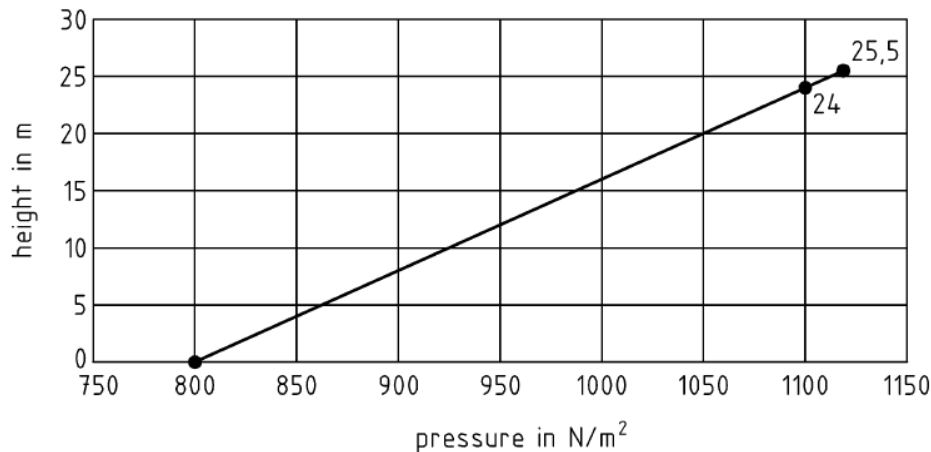

In this example, the height of the structure is 11m, so  $q_i$  on 11m is  $\pm 940$  N/m² and on 0m  $\pm 800$  N/m². When inserting one value a average of those two can be taken:  $870$  N/m².

The reference Area  $A_i$ :

Cladding condition of the system configuration	Reference area $A_i$
Unclad	Area of each component projected in the wind direction
Clad	Surface area of the cladding (see A.3 of En 12811-1:2003)

This example was an unclad example. For a component with a diameter of 48,3mm, the area is  $0,0483\text{m} \times L_{\text{component}}$ .

The aerodynamic force coefficient  $c_f$ :

Cladding condition of the system configuration	Force coefficient	
	Normal to the façade	Parallel to the façade
Unclad	1,3	1,3
Clad	1,3	0,1

In our example the structure was unclad. We will take a look at the force parallel to the façade, so  $c_f = 1,3$ .

The site coefficient  $c_s$ :

Cladding condition of the system configuration	Site coefficient	
	Normal to the façade	Parallel to the façade
Unclad	0,75	1,0
Clad	1,0	1,0

NOTE: The values for the site coefficients correspond to a façade with a solidity ratio  $\phi_B = 0,4$ ; see also EN12811-1.

For an unclad structure, the wind parallel to the façade, results in  $c_s = 1,0$ .

For each beam the force can be calculated as a line force as shown below:

$$F_K = c_s \cdot \sum_{i=1}^{i=n} A_i \cdot c_f \cdot q_i = 1,0 \cdot 0,0483m \cdot 1,3 \cdot \frac{870N}{m^2} = 54,6 \frac{N}{m} = 0,055 \frac{kN}{m}$$

This load is applied on the beams shown below (the toeboards are not taken into account, because the force coefficient is only available for tube profiles):

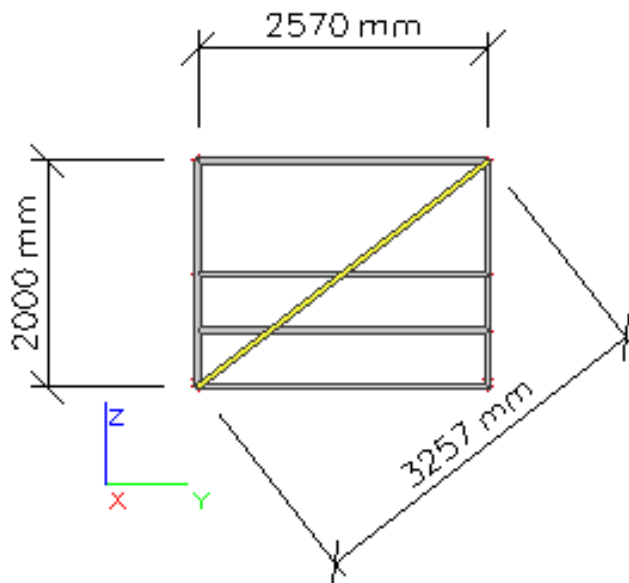

So the total force inserted is:

$$\begin{aligned} &0,055 \text{ kN/m} \times \\ &[(2+2 \times 0,5) \times 2,57m \\ &+ (2 \times 0,5) \times 2m + 3,257] \\ &= 0,055 \text{ kN/m} (12,97m) \\ &= 0,71 \text{ kN} \end{aligned}$$

In the calculation of "6. Load cases", a load of  $0,17 \text{ kN/m}^2$  has been taken into account. This value multiplied with the surface ( $= 2m \times 2,57m$ ) gives a total force of  $0,68 \text{ kN}$ .

So the two options result in a value close to each other.